



Advanced Scaffolding Learner Guide V2

High Risk Work License

**CPCCLSF4001 Licence to Erect, Alter and Dismantle Scaffolding
Advanced Level**

Learner Guide

1.6.5 Advanced Scaffolding Learner Guide V2

Course Induction

You are doing this course with National Courses Pty Ltd (RTO 41072). We trade as:



1) Identification (ID)

You must complete the state body official ID document and requirements.

2) Student Handbook

The Student Handbook was sent with your booking confirmation email.

The student handbook is an important document that explains our processes and systems and includes the following information:

- **Your rights & responsibilities**
- **Complaints, appeals & feedback**
- **Code of conduct**
- **What happens if you are caught cheating**
- **Support options**
- **Fees and refunds**
- **Privacy and data handling**
- **Certification & record keeping**

3) Training & Assessment Requirements

Your trainer will explain:

- how today's training and assessment will work
- timeframes for assessment
- assessment methods
- that training and assessment is completed in English

4) Certification Outcome

If you complete all assessment tasks satisfactorily, you will be deemed Competent and you will receive:

- A Statement of Attainment: CPCCLSF4001 Licence to Erect, Alter and Dismantle Scaffolding Advanced Level

Before leaving today, check your full name and date of birth are correct.

5) The venue

Your trainer will explain:

- Toilets and facilities
- Emergency exits and procedures
- Where to refill water bottles
- Rules regarding smoking and vaping i.e. smoking/Vaping are not allowed inside the venue. If you need to smoke or vape, you must go outside the venue.

6) Mobile Phones

During the assessment, mobile phones are strictly forbidden. All assessment answers must be completed in English without the use of a mobile phone.



7) Attendance

100 percent attendance is required for this course

8) Questions & Support

If you have questions or need support, speak with your trainer at any time. Your Learner Guide was sent via email as a downloadable link and will also be emailed again after the course with your certificate.

Your enrolment should be complete. If not, you must complete your enrolment now. If you did not provide us with a USI on enrolment it is essential you have this to us today. Please do this in your own time today and supply it to the trainer by the end of the day to not hold up and delay the class. It is not possible to get your certification without having a USI. If you have issues with the USI not matching your name, please call **1300 857 536**.

Get a USI	Find My USI
 <p>SCAN ME</p>	 <p>SCAN ME</p>

1.1 Introduction

These training materials are based on the National High Risk Licence Unit of Competence **CPCCLSF4001 Licence to Erect, Alter and Dismantle Scaffolding Advanced Level.**

You will learn about:

- Planning out your work.
- Selecting and inspecting equipment.
- Setting up for the task.
- Erecting and dismantling hung and suspended scaffolding.



1.1.1 When is a High Risk Licence Needed?



A high risk work licence allows you to lawfully work with certain high risk equipment and plant such as forklifts, cranes, hoists, elevating work platforms, scaffolding, rigging and pressure equipment. There are 3 levels of scaffolding class under a high risk licence. This course covers the work associated with the Advanced Scaffolding (SA) class of high risk work licence involving erecting, altering or dismantling a temporary structure to support a platform from which a person or object could fall more than four metres.

Competence in this unit does not in itself result in a licence. A licence is obtained after competence is assessed under applicable Commonwealth, state or territory work health and safety (WHS) regulations.

1.1.2 What Types of Work can you do with an Advanced Scaffolding High Risk Licence?

A person with an advanced scaffolding licence is legally allowed to carry out the following tasks:

- All basic scaffolding tasks:
 - Erection, alteration and dismantling of modular and prefabricated scaffolds.
 - Erection of cantilevered materials hoists with a maximum working load limit of 500 kilograms.
 - Use of ropes and gin wheels.
 - Installation of safety nets.
 - Use of static lines.
 - Erection of bracket scaffolds (tank and formwork).

- All intermediate scaffolding tasks:
 - Installation of cantilevered crane loading platforms.
 - Erection and dismantling of cantilevered and spurred scaffolds.
 - Erection and dismantling of barrow ramps and sloping platforms.

 - Scaffolds associated with perimeter safety screens and shutters.
 - Erection and dismantling of mast climbers.
 - Erection, alteration and dismantling of tube and coupler scaffolds including tube and coupler covered ways and gantries.

- Erection of cantilevered hoists.

- Erection of hung scaffolds.

- Erection of suspended scaffolds.



1.1.3 High Risk Work Licence Requirements

Once you pass your assessment you will have 60 days to apply for your licence.



You must renew your licence within 12 months of its expiry otherwise:

- Your licence can't be renewed.
- You need to repeat the course and re-apply for your licence.
- You need to enrol in the course again and be supervised by somebody who has a current licence for the same class.

You can still do high risk work without a licence as long as:

- You are enrolled in a high risk course for the class, and
- You are being supervised by somebody who has a licence for the same class.

Any licensed worker must take reasonable steps to make sure the way they work does not impact on the safety of themselves or any other worker. This is their legal duty of care. Failing to work safely can result in the health and safety regulator:

- Suspending or cancelling your licence.
- Refusing to renew your licence
- Ordering that you are reassessed to ensure you are competent.
- Taking action to prosecute.



Your employer might ask you for evidence that you have a high risk licence before you start any high risk work. You can show them:

- Your licence.
- Proof from the training company that you have passed your assessment.
- Proof that you are currently completing a course for high risk work.

1.2 Types of Scaffolding

When selecting a scaffold, the specified building's design, shape, and location should be considered.

The scaffold's ability to adapt to the structure's contours should also be taken into account.

In addition, the purpose for which the scaffold will be used should be a factor in making the decision of which type of scaffold should be selected.



You will need to decide what type of scaffold construction is the most appropriate for the tasks you need to perform.



1.2.1 Basic Level Scaffolds

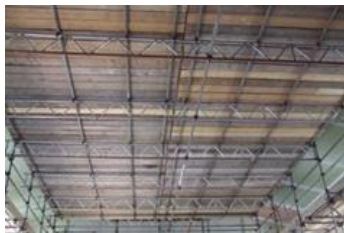

The following table outlines the main types of basic level scaffolds.

Name	Description	Example
Mobile Scaffold	A Mobile Scaffold is an independent, free-standing, movable scaffold mounted on castors. It is useful for maintenance where multiple points must be accessed.	
Birdcage Scaffold	A Birdcage Scaffold consists of more than two rows of standards, connected by ledgers and transoms. It is intended for use on one level only, and is commonly used for working on a ceiling.	

<p>Modular or Frame Scaffolding</p>	<p>A Modular or Frame Scaffolding (steel, fibreglass or aluminium) is assembled from prefabricated frames, braces and accessories.</p>	
<p>Bracket Scaffold</p>	<p>A Bracket Scaffold is a scaffold that has a platform carried on frames attached to or supported by a permanent or temporary construction.</p> <p>Bracket scaffolds are often used for maintenance work.</p>	
<p>Tower Scaffold</p>	<p>A Tower Scaffold can be a mobile, modular, or tube and coupler variety. Tower scaffolds are generally fitted with a single work platform with ladder access and have only 2 rows of standards. Tower scaffolds are popular where there is a limited amount of space to erect a scaffold.</p>	

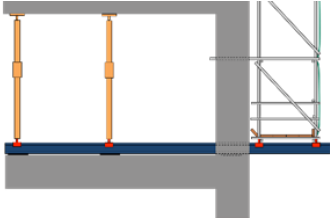
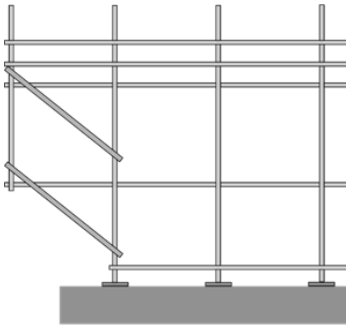

1.2.2 Intermediate Level Scaffolds

The following table outlines the main types of intermediate level scaffolds.

Name	Description	Example
<p>Tube and Coupler Scaffold</p>	<p>A Tube and Coupler Scaffold is erected using scaffold tubes connected with couplers.</p> <p>These are useful where the scaffold must be erected in a specific shape to match a structure, or prefabricated scaffolds will not meet the requirements of the task.</p>	
<p>Single Pole Scaffold</p>	<p>A Single Pole Scaffold contains a single row of standards, and is completely dependent on the structure it is placed against for support.</p> <p>A single pole scaffold is often used for bricklaying or other masonry work.</p>	
<p>Cantilever Scaffold</p>	<p>A Cantilever Scaffold is a scaffold that is supported by cantilevered load-bearing members.</p> <p>It is commonly used where surface conditions are unacceptable, or the required height of the work platform makes conventional scaffolds unsuitable.</p>	
<p>Spurred Scaffold</p>	<p>A Spurred Scaffold is partially supported by inclined load-bearing members called 'spurs'.</p> <p>They are used where there is insufficient load bearing capability for standards, or where the scaffold must be configured in a way that does not have all standards resting on the ground/supporting structure. An example of this is a scaffold that is built around and above an entryway.</p>	

1.2.3 Advanced Level Scaffolds

The following table outlines the main types of advanced level scaffolds.

Name	Description	Example
<p>Suspended or Swing Stage Scaffold</p>	<p>A Suspended or Swing Stage Scaffold can be either raised or lowered, as it has a suspended platform.</p> <p>These types of scaffolds are commonly associated with window washers.</p>	
<p>Hung Scaffold</p>	<p>Hung Scaffolds are temporary structures suspended by tubes, wire ropes or chains from a permanent structure and are used to access areas that would otherwise be difficult or unsafe to access by other means.</p> <p>They are usually made from steel, aluminium or timber components.</p> <p>Hung scaffolds CANNOT be raised or lowered when in use. Some can, however, travel horizontally with the aid of girder trolleys or mobile suspension rigs.</p>	

1.2.4 Scaffold Duty

Scaffolds have different rated capacities according to their duty:

Duty	Minimum Working Platform Width	Maximum Load Allowance on Platform
Light Duty	450mm This is the minimum clear access required for a non-working or access only platform.	225kg per bay
Medium Duty	675mm	450kg per bay
Heavy Duty	900mm	675kg per bay

The configuration and the parts that make it up generally determine the duty of a scaffold.

You need to make sure the scaffold you intend to erect will be the correct duty depending on the requirements of the job, and the types of loads that will be resting on the scaffold while it is erected.

You should check the manufacturer or supplier specifications for the exact rated capacity of the working platforms of a scaffold. Do this during the planning stage, this will make sure the scaffold can support the weight of any workers, tools, equipment and materials required for the job.

1.3 Plan the Job

Careful planning is the first step in completing a task safely.

Make sure you are aware of all of the requirements of the job, and the steps required to carry it out properly you can help to keep the work site and workers as safe as possible.

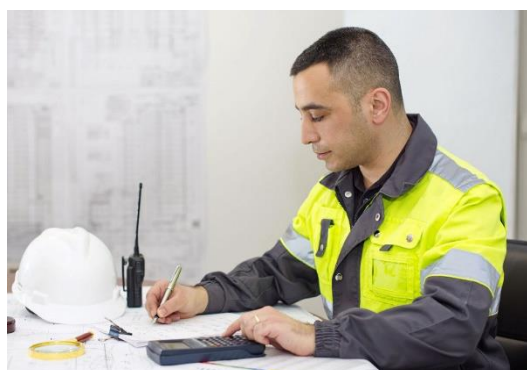

1.3.1 Assess the Task and Gather Site Information



The first thing to do when planning a task is to work out exactly what it is you need to do. Simply put, you will need to assess the task.

To do this, you will need to collect all the information you require about the tasks, personnel, local site conditions and equipment.

Site information may include details about:

- The location and specifics of the task.
- Height and width of the scaffold.
- Loads the scaffold needs to support.
- Structure condition and suitability.
- Hazards that exist on site or that are associated with the completion of the task.
- Access and egress (entry and exit) to the work area.
- Equipment that is being used on site.
- Plant and equipment required for the task.
- Availability of equipment.
- Induction and training.
- Weights and any other relevant information that can help you plan the job.



You can find work instructions, site and safety information in documentation such as:

- Work Method Statements (WMS).
- Site-specific Job Safety Analyses (JSA).
- Task plans.
- Manufacturer's specifications.
- Legislation and regulations.
- Relevant Australian Standards.
- Management Plans.
- WHS/OHS Policy.
- Code of practice.
- Operations manuals.
- Safe working or job procedures.
- Risk assessments.



Make sure you can accurately interpret and understand any structural charts and plans related to the scaffolding work. They will help you:

- Decide which scaffolding equipment and tools you will need.
- Confirm what methods and procedures you will use throughout the task.
- Identify evacuation routes no-go zones or high-risk areas on site.



When you are planning out the scaffolding task and the use of scaffolding equipment it is very important to consult with other people involved in the job. You may need to talk to supervisors, colleagues, managers responsible for workplace/operations, and other scaffolders/site workers.

1.3.1.1 Identify Forces and Loads

A 'load' is any type of force exerted on an object.

It is important to understand the relevant forces and loads that are associated with the scaffolding work you will be doing.



Forces and loads apply to scaffolds and the structures they are attached to.

When constructing a scaffold there are a range of forces and loads you may need to consider:

- **Dead Loads** – The weight of a scaffold or hoist and its components before it is loaded.
- **Live Loads** – The weight of the equipment and personnel on the scaffold (in each bay).
- **Static Load** – A load that is not moving (consistent load).
- **Dynamic Load** – Force made by a moving load on a resisting structure or component.
- **Wind Load** – The force made by wind on a structure or its components.
- **Environmental Load** – The weight of environmental factors such as water, dust and debris that may be on the scaffold.

Each standard is designed to hold at least 1/4 of the duty live load, per platform, per bay.

For example, a medium duty scaffold that can hold 450kg per bay requires each standard to hold at least 112.5kg.

It is important to know the weight of any material you place on a scaffold. If you place too much weight on a scaffold it may collapse.

Some loads may have the weight marked on them or they may come with a consignment note or weighbridge certificate.

You may have to calculate the weight of a load using appropriate mathematical procedures and formulas. Remember to add the weight of pallets, boxes and drums when lifting loads.



The weights of some common materials can be found in the table below.

Material	Weight
Cubic metre of concrete	2.4 metric tonnes
Cubic metre of water	1 metric tonne
Cubic metre of earth or clay	1.9 metric tonnes
Cubic metre of steel	7.84 metric tonnes
1000 common bricks	4 metric tonnes

1.3.2 Work Health and Safety Requirements

Work Health & Safety (WHS) is defined as laws and guidelines to help keep your workplace safe.

These can be broken down into four main types:

Law	Explanation
Acts	Laws to protect the health, safety and welfare of people at work.
Regulations	Gives more details or information on particular parts of the Act.
Codes of Practice	Are practical instructions on how to meet the terms of the Law.
Australian Standards	Give you the minimum levels of performance or quality for a hazard, work process or product such as AS/NZS 1576. Note: other valid Australian Standards may also apply.

1.3.3 Duty of Care

All personnel have a legal responsibility under duty of care to do everything reasonably practicable to protect themselves and others from harm by complying with safe work processes.

This includes activities that require licences, tickets or certificates of competency or any other relevant state and territory WHS requirements.



The following personnel have a duty of care:

- Employers and self-employed persons.
- Persons in control of the workplace.
- Supervisors.
- Designers.
- Manufacturers.
- Suppliers.
- Workers.
- Inspectors.



To meet their duty of care obligations an employer is required to provide and maintain a work environment without risks to health and safety. This includes providing and maintaining safe plant and structures as well as safe systems of work. Adequate facilities need to be provided by the employer to meet the needs of everyone on site.

They must also ensure that everyone has received adequate training, information, or supervision to complete their work. This includes providing sufficient information, training, instruction and/or supervision to individuals who have recently completed their High Risk Work Licence and are going to be completing unfamiliar scaffolding

work.

Intentionally or recklessly interfering with or misusing any WHS equipment provided by your employer is a breach in duty of care. You must cooperate with the health and safety policies and procedures set out by your employer, doing this will assist you in meeting your duty of care obligations.

1.3.4 Work Method Statements

A Work Method Statement (WMS) details how specific hazards and risks, related to the task being completed, will be managed and is developed by the employer for their workers. A Work Method Statement may also be referred to as a Safe Work Method Statement (SWMS), Safe Work Procedure (SWP) or Job Safety Analysis (JSA).

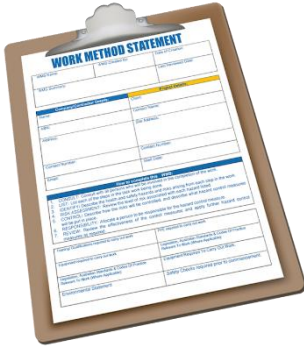

WMS fulfil a number of objectives:

- They outline a safe method of work for a specific job by identifying associated hazards and giving instructions of how these need to be managed.
- They provide an induction document that workers must read and understand before starting the job.
- They assist in effectively coordinating the work, the materials required, the time required and the people involved to achieve a safe and efficient outcome.
- They are a quality assurance tool.

The Work Method Statement must be available for inspection at all times.

As part of your job, you may be required to complete a WMS. The process below provides guidance on how to do this:

1. Break the job down into logical steps taking into consideration what is required to be achieved by the task.
2. Against each step, identify the workplace hazards in this activity i.e. the ways that a person (or plant) could be injured or harmed (or damaged) during each step.
3. Decide on measures required to mitigate hazards i.e. what could be done to make the job safer and prevent injuries or harm that may occur.
4. Identify roles and responsibilities for actions and outcomes to make sure risk/hazard controls are carried out under supervision.
5. Ensure the WMS is fully understood by all personnel prior to commencing the task.



A sample WMS is available in **Appendix A**.

1.3.5 Manufacturer Documentation

All the equipment and tools used for scaffold work, erection and dismantling will have manufacturer documentation, also called manufacturer instructions.

This documentation may include:



- Instructions for assembly and use.
- Maintenance schedules.
- End of use guidelines.
- Known hazards or risks.
- Important contact details for repairs or enquiries.

It is important that you follow the guidance provided in manufacturer documentation as this will ensure all tools and equipment are being used safely. Reviewing this documentation is an important part of meeting WHS responsibilities.

Not following guidance given in the manufacturer's instructions can lead to unsafe work practices which could lead to illness, injury or in some cases death.

Manufacturer's instructions are often referred to when conducting a risk assessment, or training personnel on how to use a new tool or install a piece of equipment.



If you are not sure where to locate these documents, then ask your supervisor or manager.

1.4 Risk Management

You may need to identify and manage risks on the work site which expose yourself, or others to injury, illness or disease. This will involve inspecting the work environment as well as the tasks being done.

A **HAZARD** is the thing or situation with the potential to cause injury, harm or damage to a person, equipment or the environment.

A **RISK** is the possibility of harm (death, injury or illness) occurring if someone was exposed to a hazard.

If you can remove or at least control a **HAZARD** you can reduce the **RISK** involved.

The aim of **risk management** is to reduce the amount of risk in the workplace, this is done by removing or managing hazards that people are exposed to at work.



1.4.1 Identifying Hazards



Part of your job is to look around to see if you can find any hazards before you start.

A good tip is to check:

- **Above head height** – remember that scaffolding may be above your head.
- **At eye level** – look around to see if there is anything in the way of where you want to place the scaffold.
- **At the supporting structure (and below)** – Have a look at the area where the scaffold connects to the structure - will it support the weight of the scaffold and load?

Common workplace hazards include:

- Ground conditions:
 - Non-weight bearing surfaces.
 - Underground hazards.
- Poor lighting.
- Overhead hazards:
 - Power lines.
 - Overhead service lines.
 - Obstructions.
 - Falling objects.
- Surrounding structures:
 - Buildings.
 - Obstructions.
 - Facilities.
 - Trees.
 - Equipment.
- Traffic:
 - Pedestrians.
 - Personnel.
 - Vehicles.
 - Mobile plant.
- Weather:
 - Wind.
 - Lightning.
 - Rain.
- Workplace-specific hazards:
 - Dangerous materials.
 - Falling from heights.
 - Hazardous manual tasks.
 - Electrical items.
 - Damaged or poor quality equipment.
 - Instability of work areas.



1.4.1.1 Consultation and Communicating with Others

Make sure you talk to the following people about hazards before you start work:



- Safety officers.
- Site engineers (where applicable).
- Supervisors.
- Colleagues.
- Managers who are authorised to take responsibility for the workplace or operations.
- Health and safety representatives.

It is important to communicate with workplace personnel and safety officers before starting on a worksite to ensure that the scaffold team is aware of any workplace policies, site-specific procedures and hazards.

1.4.2 Working Near Power Lines

Working near power lines can be dangerous if you are not careful.

It is very important that you know the safe operating distances for different types of power lines and the steps you must take if your job needs you to work closer than the safe distances.

Generally, if you need to work closer than the safe work distance you must:

- Contact the local electrical authority for permission to work closer (this is called an exemption).
- Have the power lines shut off. If this is not possible then have the power lines insulated.
- Use a spotter (depending on local laws and rules).



Distances are different depending on the state or territory you are working in and the voltage of the power lines. You should check with the local electrical authority for information and advice to find out the voltage of power lines in your work area.

Queensland

The Queensland Electrical Safety Regulation breaks down the distances in detail. Exclusion zones are broken down not only by size of power line but also by the competency level of the operator. This means that the requirements should be clarified with the electrical authority before work commences even if the distance appears to be outside the zones.

The following minimum distances are provided as guidance for any untrained person working on the erection or disassembly of scaffolds. The code of practice defines these distances under the category of a person, including any object that person is handling, not as operating plant.

Power Line Type	Distance
Up to 132kV	3.0m
Above 132kV up to 220kV	4.5m
Above 220kV up to 275kV	5.0m
Above 275kV	6.0m

New South Wales

When erecting, dismantling and using metallic scaffolding in NSW, the 4m or greater approach should be used. This is explained in the NSW Code of Practice: Work Near Overhead Powerlines. If there is a risk that 4m distance cannot be maintained between workers and overhead power lines, then the network operator should be contacted to assist in determining the safest way to complete the work.

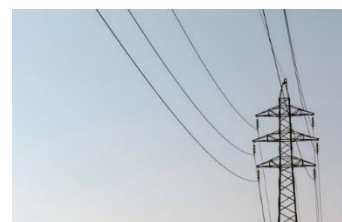

Australian Capital Territory

In the ACT mobile plant operators and persons erecting or working from scaffolding must maintain a safe minimum distance to power lines as outlined in the table below:

Power Line Type	Distance
Less than 33kv	4.0m
33kV or more (transmission lines)	5.0m

Victoria

In Victoria the Framework for Undertaking Work Near Overhead and Underground Assets states that equipment must not be closer than the following distances to power lines:

Power Line Type	Distance
Distribution lines up to and including 66kV (power poles)	6.4m (or 3.0m with a qualified spotter)
Transmission lines greater than 66kV (towers)	10m (or 8m with a qualified spotter)

Tasmania

In Tasmania equipment must not be closer than the following distances to power lines:

Power Line Type	Distance
Up to and including 133kV (poles)	6.4m (or 3m with a safety observer)
Greater than 133kV (towers)	10m (or 8m with a safety observer)

South Australia

In South Australia mobile plant operators and persons erecting or working from scaffolding must maintain a safe minimum distance to power lines as outlined in the table below:

Power Line Type	Distance
Up to 132kv (including 132kv poles)	6.4m (or 3.0m with a spotter)
132kv or more (including 132kv towers)	10.0m (or 8.0m with a spotter)

Western Australia

In Western Australia this falls under Regulation 3.64 from the OSH Regulations and states the following as the minimum distances:

Power Line Type	Distance
Up to 1kV (insulated)	0.5m
Up to 1kV (uninsulated)	1.0m
Above 1kV and up to 33kV	3.0m
Above 33kV	6.0m

Northern Territory

In the Northern Territory equipment must not be closer than the following distances to power lines:

Power Line Type	Distance
Up to and including 132kV (distribution lines)	6.4m (or 3m with a spotter)
Greater than 132kV (transmission lines)	10m (or 8m with a spotter)

1.4.2.1 Power Line Visual Indicators

There are a range of different indicators in use across the country to identify the position of overhead power lines.

Important: Visual indicators **DO NOT** insulate the power lines so exclusion zones and safe operating distances must still be used, even when any of these systems are in use.

Tiger Tails and Coloured Markers

Tiger tails or coloured markers are used to clearly show the location of overhead power lines. Poles may also be coloured up to 3m from the ground.



Marker Balls or Flags

Marker balls are fixed to the power line and are often red or another bright colour.



Safety, Warning and Danger Signs

Signage may also be present to warn of overhead power lines and services.



1.4.3 Risk Assessment

Once you have identified the hazards on site or related to the work you will be doing you need to assess their risk level.

Risk levels are worked out by looking at 2 factors:

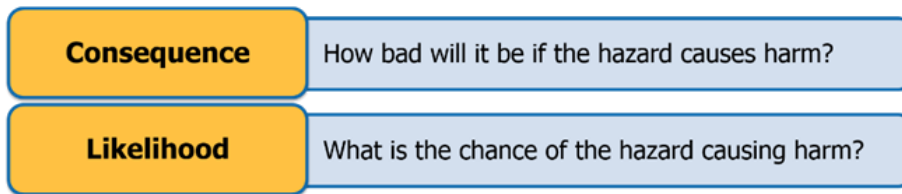

You can use a table like the one shown here to work out the risk level:

	Consequence				
Likelihood	1. Insignificant	2. Minor First Aid Required	3. Moderate Medical Attention and Time Off Work	4. Major Long Term Illness or Serious Injury	5. Catastrophic Kill or Cause Permanent Disability or Illness
1. Rare	Low	Low	Moderate	Moderate	Moderate
2. Unlikely	Low	Low	Moderate	Moderate	High
3. Possible	Low	Moderate	High	High	Extreme
4. Likely	Moderate	Moderate	High	High	Extreme
5. Almost Certain	Moderate	High	High	Extreme	Extreme

For example, a hazard that has a **Major** consequence and is **Almost Certain** to occur has a risk level of **Extreme**.



	Consequence				
Likelihood	1. Insignificant	2. Minor First Aid Required	3. Moderate Medical Attention and Time Off Work	4. Major Long Term Illness or Serious Injury	5. Catastrophic Kill or Cause Permanent Disability or Illness
1. Rare	Low	Low	Moderate	Moderate	Moderate
2. Unlikely	Low	Low	Moderate	Moderate	High
3. Possible	Low	Moderate	High	High	Extreme
4. Likely	Moderate	Moderate	High	High	Extreme
5. Almost Certain	Moderate	High	High	Extreme	Extreme

The risk level will help you to work out what kind of action needs to be taken, and how soon you need to act.

The table below is an example of a site risk policy:

Risk Level	Action
Extreme	<p>This is an unacceptable risk level. The task, process or activity must not proceed.</p>
High	<p>This is an unacceptable risk level. The proposed activity can only proceed, provided that:</p> <ol style="list-style-type: none"> 1. The risk level has been reduced to as low as reasonably practicable using the hierarchy of risk controls. 2. The risk controls must include those identified in legislation, Australian Standards, Codes of Practice etc. 3. The risk assessment has been reviewed and approved by the Supervisor. 4. A Safe Working Procedure or Work Method Statement has been prepared. <p>The supervisor must review and document the effectiveness of the implemented risk controls.</p>
Moderate	<p>This is an unacceptable risk level. The proposed activity can only proceed, provided that:</p> <ol style="list-style-type: none"> 1. The risk level has been reduced to as low as reasonably practicable using the hierarchy of risk controls. 2. The risk assessment has been reviewed and approved by the Supervisor. 3. A Safe Working Procedure or Work Method Statement has been prepared.
Low	<p>The proposed task or process needs to be managed by documented routine procedures, which must include application of the hierarchy of controls.</p>

The action you take will depend on:

-  The organisation's policies.
-  The worksite's procedures.
-  Relevant laws and regulations.

1.4.4 Hazard Controls

Once hazards and risks have been identified and assessed you need to work out what the best way to manage them will be.



The Hierarchy of Hazard Control is the name given to a range of control strategies used to eliminate or control hazards and risks in the workplace. Hazard controls should be applied before you start work, or as soon as a hazard is identified during the work.

The Hierarchy has 6 levels.

Always start at the top of the list, this is the most effective option, and work your way down.

Hierarchy Level	Explanation
1. Elimination	Completely remove the hazard. This is the best kind of hazard control.
2. Substitution	Swap a dangerous work method or situation for one that is less dangerous.
3. Isolation	Isolate or restrict access to the hazard.
4. Engineering Controls	Use equipment to lower the risk level.
5. Administrative Controls	Site rules and policies attempt to control a hazard. Includes Safe Work Practices.
6. Personal Protective Equipment	The least effective control. Use PPE while you work. This should be selected at the planning stage of your work, and checked before starting the job.

You may need to use a range of control measures to reduce the risk to an acceptable level.

Hazard controls need to be implemented before you start work or as soon as a hazard is identified during the work.

1.4.4.1 Controlling Traffic Hazards

If the work area is going to be shared with pedestrians, site personnel, vehicles or mobile plant, you will need to make sure you have selected appropriate control measures.

This may involve isolating the work area by setting up barricades and signage to warn others that you are working in the area and that it is dangerous for them to come too close.



This may include:

- Using a flag person to control traffic.
- Setting up flashing hazard lights.
- Organising hoardings, gantries or scaffolding.
- Setting up warning signs and barriers.
- Setting up pedestrian and vehicle exclusion zones.

Worksites that require the management of traffic will have a traffic or vehicle management plan. These plans will show you where to place hazard controls including signage, barricades and flag persons.

1.4.4.2 Controlling Equipment Hazards



If the scaffold is to be constructed within the working radius of a crane on site, or close to other equipment with moving parts there is a hazard of the scaffolding being struck or hit by the crane or equipment.

In this situation you will need to implement a number of control strategies including:

- Safety exclusion zones to prevent unauthorised access to the dangerous area – this may include a flag person.
- Workplace communications to assist in coordinating movements within the work area.
- Barriers or other physical means of preventing the equipment from making contact with the scaffold or injuring personnel on site.

1.4.4.3 Hazard Controls for Work at Heights

Working at heights can be very dangerous if the right control measures are not put into place. You must follow all safety rules and instructions when performing any work at heights.

In instances where it is not possible to eliminate the risk of falls, the following risk controls can be used to reduce the risk of falling from heights:

- Installing temporary platforms.
- Completing working at heights training.
- Following safe work procedures.
- Using edge protection.
- Using fall arrest systems.
- Establishing exclusion zones.
- Establishing safe and adequate access and egress.
- Ensuring adequate illumination of the work site.

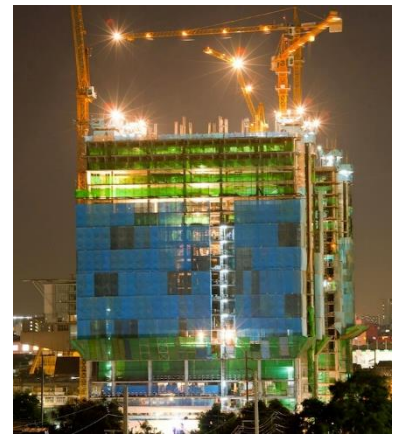

2.1 Prepare for Scaffolding Work



You will need to plan all the details of how you intend to carry out the task, how you intend to deal with any unidentified hazards and what components you will use to complete the scaffold.

You should document these details in a scaffolding plan.

The procedures and techniques you plan to use to complete your tasks should conform with all legal requirements related to scaffolding work.

Scaffolding plans are used to make sure everyone clearly understands what they need to do to meet safety requirements and avoid misunderstandings on site.

2.1.1 Scaffolding Plan

The details of the scaffold plan may include:

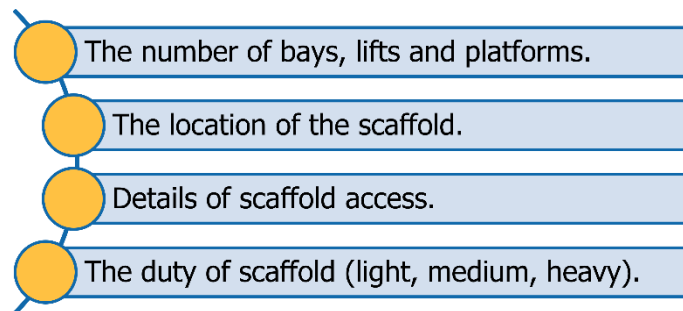

When you are putting the scaffolding plan together you should consult with other people involved in the job. They may have expertise or experience that is valuable to the planning of the task.

Personnel you may consult with include:

- Supervisors.
- Designers or engineers.
- Doggers or riggers.
- Managers responsible for workplace/operations.
- Other scaffolders/site workers.





Your plan will need to refer to other relevant plans, drawings and documentation such as work method statements or site procedures.

These documents can be used as a reference to determine the scaffold equipment and parts that are required to erect the scaffold and the configuration of work platforms, ladder access and other components or associated equipment.

Make sure everybody involved in the scaffolding work is familiar with the plan and understands what they need to do.

If the scaffolding task requires you to erect a swing stage you will need to identify and select the following:



- Type and size of platform.
- Method of sideways (lateral) movement.
- Hoist type and capacity.
- Method of fixing needles/rigs.
- Any other job or site requirements that require specific equipment (e.g. overhead protection in platform).

Make sure that all components that make up the swing stage are appropriate for the job and in safe working order.

2.2 Identify, Select and Inspect Equipment

A scaffolding task may require the use of a wide range of scaffolding, associated and safety equipment to be used and installed.

Part of completing the planning for the scaffolding job is to identify what equipment you will need, then select and inspect that equipment to make sure it is safe for use.

It is very important that you check all equipment before you use it to ensure that it is safe to use and suitable for the task.



You may need to consult with other people involved in the job such as supervisors, colleagues, managers, other scaffolders, and site personnel when identifying the equipment needed to carry out the scaffolding task.

2.2.1 Identify, Select and Inspect Associated Equipment

The erection, alteration and dismantling of scaffolds requires you to use a range of equipment, this may include:



- Planks.
- Ladders and stairways.
- Scaffold tubes.
- Couplers and fittings.
- Fibre ropes and Flexible Steel Wire Rope (FSWR).
- Chains.
- Screening.
- Adjustable props.
- Prefabricated needles.
- Counterweights.
- Beam clamps.
- Trolleys.
- Hand tools.

Check that all components are not damaged or worn. Check that all components fit together securely.

2.2.1.1 Scaffold Planks

Planks are used to construct working platforms. They can be made of timber, or metal (aluminium or steel).

Planks should have the correct information displayed upon them.



The usual width of a scaffold plank is 225 mm. The usual thickness of a hardwood solid timber scaffold plank is 32 mm.

Do not use scaffold planks with any of the following faults:

Possible Timber Plank Defects:	
Markings are missing , incomplete or illegible (refer to AS/NZS 1577).	End fixing is missing.
Width is less than 220mm.	Painted or treated which may conceal damage.
Thickness has been reduced by more than 10%.	Deep burns.
Laminations are separating in a laminated plank.	Deep oil stains causing the plank to be slippery.
Warped, twisted, broken, split or worn.	Nails projecting/any kind of rot.
End hoop iron is broken or damaged.	Knots present.

Possible Metal Plank Defects:	
Twisted.	Broken weld reinforcing strap.
Distorted.	Markings are missing.
End cap missing.	Width is less than 220mm.
Crushed.	

If any of these are present then the plank **MUST NOT BE USED!**

2.2.1.2 Ladders

Ladders are used to access a scaffold.

Ladders or stairways or ramps must always be installed on scaffolds when there is no other direct access from the same level. This applies even when other access equipment (e.g. personnel hoists) is available and installed.

You can only use a single industrial grade ladder to access a scaffold.

DO NOT use a domestic grade ladder.



Fix the ladder at a slope not less than 61 and not more than 4:1. Make sure they are secure and extend above landings by at least 900mm.

It is vital that you only use ladders that are in good working order.

Possible Ladder Defects that will Condemn a Ladder from Being Used for Scaffolding Access:	
Timber stiles are warped, splintered, cracked or bruised.	Ropes, braces or brackets are missing, worn or broken.
Metal stiles are twisted, bent or kinked.	Tie rods are missing, broken or loose.
Crushed damaged welds or damaged feet.	Ladder is not industrial strength.
Rungs, steps, treads or top plates are missing, worn, damaged or loose.	Timber parts (apart from narrow identification bands) are covered with opaque paint or other treatment that could disguise faults.

If any of these are present then the ladder **MUST NOT BE USED!**

2.2.1.3 Scaffold and Tie Tubes

Scaffold Tubes

Scaffold tubes may be made from aluminium or steel.

The minimum outside diameter of a common scaffold tube is 48mm.

The minimum wall thickness of a common steel scaffold tube is 4mm.



The minimum wall thickness of a common aluminium scaffold tube is 4.45mm (or 4.4mm or 4.5mm).

Possible Scaffold Tube Defects:	
Pitted.	Flame cut.
Bent.	Cross cut.
Split ends.	Mushroom headed.
Tube wall thickness less than minimum requirements.	Heavily corroded.

If any of these are present then the scaffold tube **MUST NOT BE USED!**

Tie Tubes



Tie tubes are used to fix a scaffold to the structure to provide support and stability. This keeps the scaffold erect, level and stable. Generally, they are connected to the scaffold using a right-angle coupler.

Check that they are not damaged or worn and that the scaffold tubes connect properly.

2.2.1.4 Couplers and Fittings

Couplers (or clips or fittings) are used to join two scaffold tubes. There are many different types of coupler including:

- **Right-angle coupler** – A non-swivel loadbearing coupler, other than a putlog coupler, that connects two tubes at right angles.
- **Swivel coupler** – A coupler used for connecting two tubes at any angle.
- **Putlog coupler** – A coupler for fixing a putlog to a ledger.
- **End-to-end coupler** – Internal expanding joint pin that connects and aligns the tube end-to-end.
- **Sleeve coupler** – An external end-to-end coupler for joining two tubes.
- **Parallel coupler** – A coupler for making a lap or spliced joint between two tubes.



The following scaffold tubes may not be joined end-to-end:

- Ties.
- Transoms.
- Ledgers (if the join will occur within the end bay of a scaffold).

There are two methods of tightening a coupler:

Screw-Tightened Coupler	A coupler in which the clamping force on the tubes is provided by tightening the flaps around the tube by means of a bolt and nut.
Wedge-Tightened Coupler	A coupler in which the clamping force on the tubes is provided by tightening the flaps around the tube by means of a wedge hammered into place.

Do not use couplers with any of the following faults:

Possible Coupler Defects:	
Damaged hinges.	Damaged threads or nuts.
Excessive oil, grease or paint.	

If any of these are present then the coupler **MUST NOT BE USED!**

When couplers are used to prevent movement (as opposed to connecting scaffold tubes) they are referred to as 'check couplers'. Check couplers may be a right angle coupler, swivel coupler or parallel coupler that is fixed hard up against a loadbearing coupler to increase the slip resistance along the tube.



Different configurations of scaffold tubes require check couplers to prevent unwanted movement and keep the scaffold stable and secure.

Check couplers should be positioned to prevent movement caused by compression or tension (depending on the configuration). You need to identify whether the affected tubes are in tension or compression.

2.2.1.5 Fibre Ropes and FSWR



Fibre ropes can be used for lifting and temporarily securing components during the erection and dismantling of the scaffold.

The minimum diameter of fibre rope you would use for a hand line is 12 mm.

To determine the rated capacity of fibre rope use the formula:

$$\text{Rated Capacity} = D^2 \text{ (mm)}$$

OR

$$\text{Rated Capacity} = \text{Diameter (mm)} \times \text{Diameter (mm)}$$

You must check any fibrous ropes carefully before using them. The checklist below outlines what you are looking for. If a rope shows any of these it is unsuitable for use.

Possible Fibrous Rope Defects:	
Broken fibres/strands.	Stretched rope (overloading).
Excessive wear.	Abrasion.
High stranding.	Chemical exposure.
Brittleness.	Discolouration due to excessive heat.
Sun rot.	Mildew.
Knots.	

If any of these are present then the rope **MUST NOT BE USED!**

Flexible steel wire ropes (FSWR) are used for the termination of static lines and as guys for cantilever hoists and scaffolds.



To determine the rated capacity of FSWR use the formula:

$$\text{Rated Capacity} = D^2 \text{ (mm)} \times 8$$

OR

$$\text{Rated Capacity} = \text{Diameter (mm)} \times \text{Diameter (mm)} \times 8$$

You must check any FSWR carefully before using it. The checklist below outlines what you are looking for. If a FSWR shows any of these then it is unsuitable for use.

Possible FSWR Defects:	
Missing or illegible rated capacity markings.	Excessive number of broken wires.
Bird-caging (Strands loosened from proper tight lay).	Severe kinking or fractures from bending or reeving.
More than 10% wear in the rope diameter.	Crushed/damaged strands.
Splice, ferrule, eye or thimble damage.	Abrasion wear.
Squashed FSWR.	Stretched or overloaded FSWR.
Knotted FSWR.	Core collapse.
Severe/serious corrosion (indicated by loose and springy wires).	High stranding.
Chemical exposure.	High temperature exposure.

If any of these are present then the rope **MUST NOT BE USED!**

2.2.1.6 Chains

Short link chains may be used to support hung scaffolds. The barrel of short link chain requires a greater force to bend, provides greater strength, reduces the tendency to twist and provides better reeving performance.



These chains must be Grade T and not less than 8mm in diameter. Grade markings or letters denoting the grade are stamped or embossed on the chain at least every metre or every 20 links, whichever is less.

Chains should be checked before and after use to make sure they are in safe working condition. The checklist below outlines what you are looking for. If a chain shows any of these then it is unsuitable for use.

Possible Chain defects:	
Missing or illegible rated capacity tag.	Stretching, locked, movement restricted.
Incompatible grade and diameter components.	Squashed/crushed more than 10% of original link diameter.
Cracks in link welds, spot-welding.	Gouged/cut more than 10% of original link diameter.
Exposure to excessive heat.	Severe/excessive rust or corrosion.
Pitting.	Twists and/or kinks and/or knots.
Excessive wear on chain (over 10% wear in link diameter).	

2.2.1.7 Screening



Sheeting or screening is used to protect workers from environmental hazards such as dust and sunlight.

Do not use flammable material such as hessian for sheeting.

An engineer should always check the design of a sheeted scaffold.

2.2.1.8 Adjustable Props

Adjustable props are used to support temporary beams (needles) for cantilevered scaffolds and similar equipment, such as cantilevered crane loading platforms (CCLP).

They can also be used to secure suspension rigs/prefabricated needles that are located within a structure (floor above and below).

Generally, adjustable props come with two mechanisms for adjustment:

- A pin (sometimes called a prop or “G” pin) is used for coarse adjustments.
- A threaded collar is used for fine adjustments.



Make sure that all parts move and lock properly and that the prop is rated for the job. If you are unsure check with the manufacturer.

2.2.1.9 Prefabricated Needles/Suspension Rigs & Counterweights

Prefabricated needles or suspension rigs are used to support a suspended scaffold. These are purpose built and designed to support a specific amount of weight.



Some needles/rigs may be mounted to a rail allowing lateral (sideways/horizontal) movement.

These needles/rigs are often used in conjunction with purpose designed counterweights.

Counterweights may be used to help support a suspended scaffold that is attached to a prefabricated needle or suspension rig.

It is important that these counterweights are secured to prevent any accidental removal while the scaffold is in use.

2.2.1.10 Beam Clamps

Beam clamps are used to attach slings that are supporting a hung scaffold to a steel beam (RSJ).



2.2.1.11 Trolleys

Trolleys are used to secure a scaffold to a beam or girder flange allowing the scaffold to move side to side.



2.2.1.12 Hand Tools

There are many different tools and maintenance equipment you can use for the various different tasks needed to construct a scaffold including:

- Tape measures.
- Podgers.
- Wrenches.
- Cutters.
- Wire nips.
- Hammers.
- Sledge hammers.
- Hammer drills.
- Shovels.
- Wheelbarrows.
- Spirit and torpedo levels.
- Spanners and box spanners.



A scaffold belt can be used to carry hand tools while working.

All tools and equipment used for the erection, alteration and dismantling of scaffolds must be used in accordance with the manufacturers specifications, organisational policies and procedures and safe work practices.

Read the operators manual before using any equipment for the first time.

Do not exceed the limitations of the equipment – it could be extremely dangerous and could damage the equipment.

Always check that all tools and equipment are functioning correctly and that they do not show any signs of damage or wear.

2.2.1.13 Materials Hoists

Materials hoists are used to lift and lower materials between the ground and a working platform.

Materials hoists must be set up on solid timber packing and run up and down the outside of a tower using a wire rope hoisting system for raising and lowering the platform.

They are designed to transport materials only and personnel should never ride on the hoist.

Always refer to the manufacturer's operating manual for directions on how to set up and operate the materials hoist safely.



Check that all parts are present. Check for any signs of damage or wear. Always refer to the manufacturer's instructions when inspecting the materials hoist components.

2.2.1.14 Swing Stages

If the scaffolding task requires you to erect a swing stage you will need to identify and select the following:



- Type and size of platform.
- Method of sideways (lateral) movement.
- Hoist type and capacity.
- Method of fixing needles/rigs.
- Any other job or site requirements that require specific equipment (e.g. overhead protection in platform).

Make sure that all components that make up the swing stage are appropriate for the job and in safe working order.

You will need to check for signs of damage or wear on:

If anything looks unsafe or out of order you must not use it.

- The cradle/platform.
- The control box.
- Hoists.
- Hoist ropes.
- Safety or limiting devices.
- Suspension rigs.

2.2.2 Identify Safety Equipment

Depending on the requirements of the job, you may need to use safety equipment to reduce the risk to an acceptable level.

Safety equipment includes:

- Safety harness.
- Lanyard.
- Energy absorber.
- Inertia reel.



All safety equipment should be selected at the planning stage. Safety equipment needs to be inspected before and after use.

2.2.2.1 Safety Harnesses

In most cases of working at heights a full body harness should be worn.



Harnesses must:

- Be correctly fitted in accordance with manufacturer's instructions to ensure effectiveness.
- Meet the requirements of AS/NZS 1891 Industrial fall-arrest systems and devices.

Workers should connect the fall-arrest line to the attachment point on their harness (dorsal attachment point in the middle of the back, or the chest connection) that will provide the best protection for the situation it is being used.

A fall-arrest harness must be inspected before use.

Common defects that will condemn a safety harness from use are:

- Fraying.
- Splitting.
- Any obvious signs of damage to any part of the harness.

Shown here are some examples of things you need to check the harness for:

Component	Condition/Fault to be Checked
Webbing	<ul style="list-style-type: none"> • Cuts or tears. • Abrasion damage. • Excessive stretching. • Damage due to contact with heat, corrosives or solvents. • Deterioration due to rotting, mildew, or ultraviolet exposure.
Snap Hooks	<ul style="list-style-type: none"> • Distortion of hook or latch. • Cracks or forging folds. • Wear at swivels and latch pivot pin. • Open rollers. • Free movement of the latch over its full travel. • Broken, weak or misplaced latch springs (compare if possible with a new snap hook). • Free from dirt or other obstructions, e.g. rust.
D-rings	<ul style="list-style-type: none"> • Excessive 'vertical' movement of the straight portion of the D-ring at its attachment point of the belt, so that the corners between the straight and curved sections of the D become completely exposed. <p>NOTE: Excessive vertical movements of the D-ring in its mounting can allow the nose of larger snap hooks to become lodged behind the straight portion of the D, in which position the snap hook can often accidentally 'roll out' of the D under load.</p> <ul style="list-style-type: none"> • Cracks, especially at the intersection of the straight and curved portions. • Distortion or other physical damage of the D-ring. • Excessive loss of cross-section due to wear.
Buckles and adjusters	<ul style="list-style-type: none"> • Distortion or other physical damage. • Cracks and forging laps where applicable. • Bent tongues. • Open rollers.
Stitching	<ul style="list-style-type: none"> • Broken, cut or worn threads. • Damage or weakening of threads due to contact with heat, corrosives, solvents or mildew.

2.2.2.2 Lanyards and Energy Absorbers

Lanyards are used to stop tools falling from heights. These lanyards are connected to the tool and wrap around the wrist or belt of the scaffolder.

To reduce injuries caused by a fall, energy absorbers should be used as part of the fall arrest system.

The energy absorber should restrict the fall distance to a maximum of 2 metres before the fall-arrest system takes effect.



There should be a minimum of slack in the fall-arrest lanyard between you and the anchor point, which should be as high as the equipment permits.

Avoid work above the anchor point, as this will increase the free fall distance in the event of a fall, resulting in higher forces on the body and greater likelihood of the energy absorber snagging on obstructions.

2.2.2.3 Inertia Reels

Inertia reels provide a worker with a relatively free range of movement or extra reach compared to a lanyard. These have the added safety feature of being able to lock in the event of a fall, arresting the descent of the worker.



Inertia reels must comply with AS 1891.3 Fall-arrest devices.

Inertia reels should not be used in the following situations:

- While working on a sloped surface (e.g. a steeply pitched roof) or any other surface where a fall may not be a quick vertical one.
- Locked as a constant support for a worker during normal work.
- In conjunction with a lanyard.

Shown here are some examples of some things you need to check an inertia reel for:

Component	Condition/Fault to be Checked
Rope (Fully Extend and Rewind Drum Anchorages)	<ul style="list-style-type: none"> • Cuts. • Abrasions or fraying. • Stretching. • Damage due to contact with heat, corrosives, or solvents. • Excessive dirt or grease impregnation. • Check that the rope end is securely anchored to the drum.
Anchorage Body	<p>a) Mountain ring:</p> <ul style="list-style-type: none"> • Physical damage or wear. • Cracks. • Mounting security. <p>b) Anchorages body proper:</p> <ul style="list-style-type: none"> • Physical damage. • Check for the entry of foreign bodies. • Loose or missing screws, nuts or similar objects. • Position of the clutch compression indicator button.
Locking Mechanisms and Rope Guides	<ul style="list-style-type: none"> • Check rope guides for excessive wear or ridging. • Check that the rope-locking mechanism locks and holds securely. • Ensure that the rope runs freely through the anchorage, and that on rewind drum anchorages the rope rewinds completely without loss of tension.
Hardware	<ul style="list-style-type: none"> • Examine the condition and locking action of any associated snap hooks or links.

2.3 Work Site Communication

You should always communicate with those around you while you work. Make sure you understand any instructions given to you.

Communication procedures can include:

- Manufacturer's guidelines (instructions, specifications, checklists).
- Industry operating procedures and relevant codes of practice.
- Workplace procedures (work instructions, operating procedures, checklists).
- Reporting and recording procedures (equipment defect/s).



Following these procedures will ensure that everyone clearly understands what their tasks are on site and how to complete them safely.

2.3.1 Communication Methods

Talk to the appropriate personnel (e.g. supervisors, colleagues or managers) to discuss the best methods for communication while you are still at the planning stage of the job.



Workplace communications may take the form of:

- Verbal and non-verbal language.
- Written instructions.
- Signage.
- Hand signals.
- Listening.
- Questioning to confirm understanding, and appropriate worksite protocol.
- Toolbox meetings.

Reaching an agreement with other personnel on site about the best communication methods is important. It will make sure everyone knows what is expected of them when they are communicating or receiving information.



These expectations can be communicated during the work site induction process or found in policies and procedures.

2.3.2 Select and Inspect Communications Equipment



Most worksites use two-way radios for communication. The 2 types are conventional and fixed.

It is important that any two-way radio system provides clear signals without any interference on the channel.

Therefore it is important to select communication equipment that is appropriate to the work to be undertaken and the site on which you will be working.

Make sure all equipment is working properly and that you can communicate with other workers clearly (without interference) BEFORE you start the job. This means that any communication equipment should be inspected before use for faults or defects and proper functioning. Do not use any communication equipment that is not considered to be in working order.

2.3.2.1 Conventional Radio

Great care must be taken when allocating frequencies/channels to make sure that there are no other operators using the same frequency in the area.

Interference on your frequency can be a safety hazard. Stop work until the radio is checked or a new frequency selected and allocated.



2.3.2.2 Fixed Channel Radio

Fixed channel radio is a computer controlled two-way system that locks other radio users out of your selected frequency.

With a fixed channel radio it is possible to have several separate groups on one site communicating by radio without interfering with each other.

This radio is recommended for large sites.



Review Questions

2.4 Defective Equipment

If you identify any equipment that is defective, damaged or faulty you must not use it. Doing so could risk the safety of yourself or others on site.

If you are unsure of if the equipment is defective, consult with your supervisor or manager for guidance.



2.4.1 Isolate Defective Equipment

Defective equipment needs to be isolated from use to stop anybody from accidentally using it. The defect needs to be reported to an authorised person as soon as practicable.

Your worksite will have isolation procedures for defective equipment you must follow.

This may include tagging or locking out equipment and completing fault reports or other documentation.



Faulty equipment may need to be labelled and rejected, destroyed or returned to the manufacturer for repair (depending on the type and severity of the fault).

Scaffolding components that are identified as faulty or unsafe must be tagged and removed from site.

Review Questions

2.5 Set Up for the Task

Once you have selected all of the equipment you will need and made sure it is safe to use you will need to start setting up for the task.

Planning and preparation are essential to conducting the work safely and on schedule.

This includes:

- Implementing hazard controls/treatments as required.
- Checking the ground suitability where the scaffold is going to be erected.
- Preparing the footings for the scaffold to ensure stability throughout the erection process.
- Preparing any scaffold and associated equipment for erection.
- Fitting and securing safety equipment in accordance with procedures.
- Positioning equipment for the work application and stability.

2.5.1 Apply Hazard Control Measures



Once you are ready to start setting up the scaffold make sure you have implemented the necessary hazard control measures.

Talk to other workers in the area to make sure they are aware of the control measures you intend to use.

Always wear the required PPE for the job. Make sure that any control measures are consistent with workplace and safety standards. If you are unsure, check with your WHS officer or supervisor.

Hazard prevention/control measures may include:

- Power line warning systems (e.g. Tiger tails).
- Power disconnected by competent authority (where applicable).
- Safe and adequate access and egress (entry and exit).
- Safety tags on electrical switches and isolators.
- Safety observer (spotter) inside an exclusion zone (e.g. power lines).
- Setting up adequate lighting in the work area.
- Setting up barricades and traffic control to keep the area below the scaffold clear.
- Pedestrian control (barricades, signs, etc.) to limit the number of people in the area below the scaffold.
- Moving any obstructions out of the way.



Some hazards are caused by the work being done so you may need to implement hazard controls before the work begins. Make sure to move obstructions such as equipment, materials or debris, or install trench covers if working near excavations.

Always wear the required personal protective equipment (PPE) for the job. Make sure that any control measures are consistent with workplace and safety standards. If you are unsure, check with your WHS officer or supervisor.

2.5.2 Check Structural Load Bearing Capacity



You must check the load bearing limits of any surfaces or structures which scaffolding, or equipment will be fixed to or supported by. This could include:

- Concrete floors.
- Building roofs and landings.
- Bridges.



The pressure of the equipment could cause damage to the surfaces or structures the scaffolding is fixed to or supported by. Likewise, the scaffolding and equipment could be damaged if erected on or supported by a surface that is uneven or structurally compromised.

If scaffolding or equipment is positioned on the ground then you may seek the advice of a competent person such as an engineer with experience in scaffolding structural design/analysis and knowledge of the relevant Australian Standards (such as AS 1576). Someone with this type of expertise can provide information on the load bearing capacity of the ground.

To make sure the ground is strong, firm and level enough to keep the scaffold erect, level (horizontally straight), plumb (vertically straight) and stable you need to know two (2) things:

- The weight of the scaffold.
- The load bearing ability of the surface.

If the ground is uneven then materials may need to be added or removed to fix this. Doing this is called levelling. This will require specialised equipment, personnel expertise, and calculations.

Dead Load Weight

- = The weight of the baseplate.
- + The weight of the standards.
- + 1/2 the weight of any transoms connected to the standards.
- + 1/2 the weight of any ledgers connected to the standards.
- + 1/2 the weight of each brace connected to the standards.
- + 1/4 of the weight of all planks supported by the standards.



2.5.3 Prepare Footings and Foundations



A scaffold must have a firm footing to keep it stable and secure.

Sole plates/boards and base plate or screw jacks are used to provide a secure foundation.

The size of a sole plate depends on the combined dead load, and the live load weights. To work out how long these need to be you need to know the total weight that will be placed on the specific sole plate and the weight bearing ability of the ground you are setting up on.

To work this out add the dead load to the live load (the live load is calculated as 1/4 of the scaffold duty per platform, per bay) and divide the answer you get by the load bearing pressure (measured in kg/m²), then divide this answer by the width of the sole plate to determine the required length of the sole plate.

2.5.4 Fit Safety Equipment

All safety equipment needs to be fitted before starting the scaffolding work. You need to make sure it is appropriate for the task and that it fits you correctly.

Never begin a scaffolding task without the appropriate safety equipment.

Safety systems (such as static lines) and working at heights where there is a chance of falls, require the use of a full body fall-arrest harness and installed anchor points.

Safety equipment also includes Personal Protective Equipment (PPE). Always make sure you are wearing the correct PPE for the task and worksite.

Generally, at a minimum this would include:

- Hard hat/safety helmet.
- Safety gloves.
- Steel-capped work boots.
- High-visibility clothing.
- Fall arrest harness.



Check for signage on site or talk to a manager or supervisor if you are unsure of the PPE requirements for the site.

2.5.5 Prepare and Position Scaffolding Equipment

All equipment and scaffolding needs to be prepared in line with site procedures, the scaffolding plan and the manufacturer's specifications before you start the work.



Any equipment and plant that you will be using throughout the scaffolding work needs to be correctly and safely positioned. This could include positioning plant and equipment or moving scaffolding components into position where it can be safely accessed.

It also includes coordinating resources so that you have everything that you need in or close to the work area.

This will allow you to erect the scaffold and equipment without having to continuously leave the work area, or disrupt operations that may be taking place elsewhere on the worksite.

3.1 Erect Scaffold and Scaffold Equipment

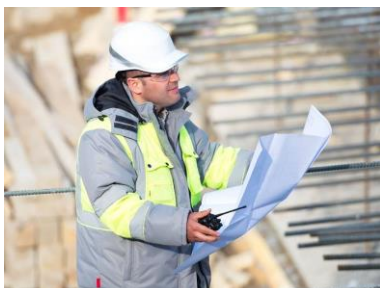

Erecting a scaffold and scaffold equipment requires careful planning, knowledge of equipment and procedures, accurate site information and good communication skills.

Equipment should be unloaded as close as possible to the work area and arranged in a logical order.

An engineer will also need to be consulted with in determining the weight bearing capacity of the surface the scaffold will be erected on compared to the size and weight of the scaffold.

3.1.1 Suspended Scaffolds

A suspended scaffold is used for short term work on the sides of tall buildings or structures where access by other means is limited by the height of the work being carried out.

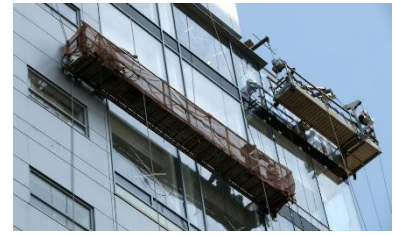

These scaffolds are made up of a cradle (platform) that is supported by temporary supporting structures and can be raised and lowered using flexible steel wire rope (FSWR) hoists. These are the same as the type of scaffolding used by window washers.

Suspended scaffolds include:

Swing Stages

A suspended cradle connected to suspension ropes at either end – the most common suspended scaffold.

Double Rope

Same concept as swing stage but with 2 suspension ropes supporting each end of the cradle.

Work Cages

A small suspended cradle supported by only 1 rope, usually designed for a single person.

All suspended scaffolds and suspension rigs being erected or altered must meet the relevant compliance requirements including:

- Engineering specifications.
- Manufacturer's specifications.
- AS1576.4 Suspended scaffolding.

For further information about the erection and alteration of suspended scaffolds and suspension rigs, refer to the design specifications.



The supporting structure should be assessed by a competent person such as an engineer with experience in scaffolding structural design/analysis and knowledge of the relevant Australian Standards before the suspended scaffold is erected.

Personnel with this expertise can assess whether the building or structure to which the suspended scaffold is to be mounted will be able to support the scaffold as well as all loads placed upon it (e.g. dead loads, live loads, wind loads).

After the assessment, they will provide the party responsible for the scaffolds erection with a statement to confirm that the structure has been determined to be suitable for the installation of a suspended scaffold.

Stability equipment may be installed to steady the scaffolding, this includes:

- Lanyards.
- Tensioned wire ropes.
- Removable ties.
- Fan units.
- Suction units.



To meet WHS requirements a safety harness and lanyard must be used when the scaffold is not able to be accessed from the ground, or a protected landing. These must be attached to a suitable anchorage (rated to 15kN for a single person up to 21kN for two (2) people) to make sure there is safe access to the scaffold cradle/platform.

3.1.1.1 Swing Stages

A swing stage provides a suspended work platform for multiple personnel that is able to be raised and lowered using manual, pneumatic (air) or electric hoists. A swing stage may be made up of the following components:

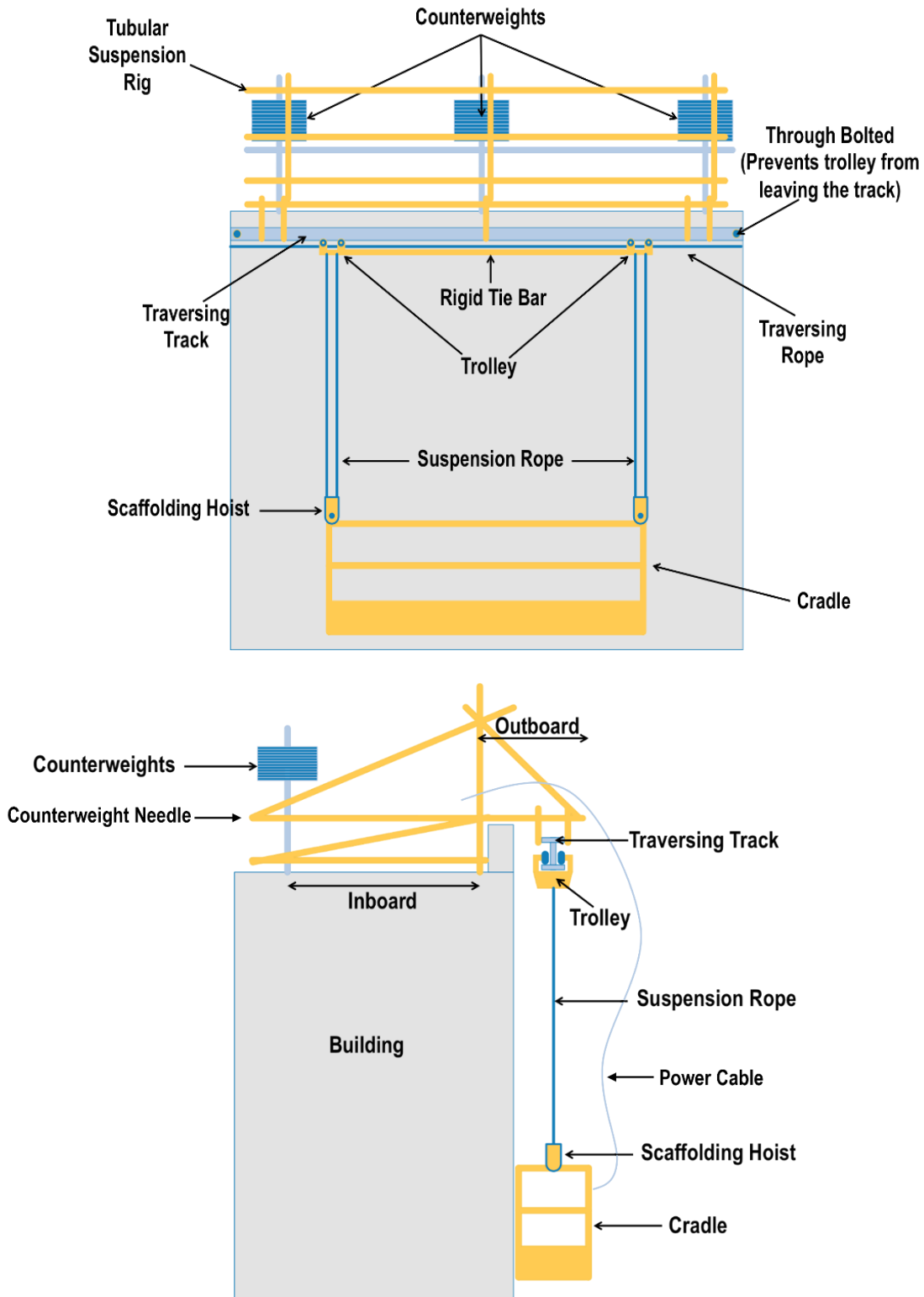

3.1.1.2 Safety Considerations of Suspended Scaffolding Cradles

There are minimum safety requirements different parts of the scaffolding is expected to comply with. This includes requirements for the:

- Cradle.
- Hoists.
- Suspension and Secondary Ropes.
- Suspension Rigs.
- Counterweights and Tracks and Trolleys.



These requirements must be met to remain compliant with WHS requirements on site. Doing this will ensure the health and safety of those using the scaffolding, erecting it and nearby (e.g. pedestrians).

Cradle

All scaffold cradles must meet some basic safety and construction requirements. The cradle width requirements for different scaffolds are:

Scaffold Type	Minimum Cradle Width	Maximum Cradle Width
Double Rope Suspended Scaffold	900mm	1.7m
Swing Stage	450mm	900mm
Suspended Work Cage	700mm	1.5m

Other requirements include:

Item	Requirements
Cradle	<ul style="list-style-type: none"> • Should be fitted with: <ul style="list-style-type: none"> ○ Guardrails. ○ Mid-rails. ○ Toe-boards. • Working deck safely secured to prevent movement. • Slip resistant with adequate drainage holes. • Free from trip hazards. • Up to a 3° degree slope in all directions is allowable in the scaffold platform, unless otherwise specifically designed. • Access between levels of a multi-tiered cradle should be fitted with: <ul style="list-style-type: none"> ○ Protective mesh. ○ Hinged trapdoors or sliding hatches. ○ If there is no access between levels then the scaffold should be able to be operated from any level. • The stabilising sheave above the platform of a work cage should be at a height of at least 2 metres. • Rated capacity should be displayed on the inside.

Protection and Safety	<ul style="list-style-type: none"> • Netting, if fitted to prevent materials falling from the cradle, should: <ul style="list-style-type: none"> ○ Be constructed of galvanised wire mesh, at least 1.5mm thick. ○ Have wires spaced at least 20mm apart. ○ Be fixed between the toe-board and guardrail on all sides. • Overhead protection may need to be installed above a cradle if there is a likelihood of debris falling onto the scaffold.
Control Boxes	<ul style="list-style-type: none"> • Should be fully enclosed, lockable and protected from shock or environmental damage. • Should be attached to the inside of the guardrails away from the working face. • They should be removable so they can be secured safely when not in use. • Should be fitted with: <ul style="list-style-type: none"> ○ Socket outlets for hoists. ○ A power on light indicator. ○ An emergency stop button.
Rated Capacity	<ul style="list-style-type: none"> • Should be displayed on a sign inside the cradle. <ul style="list-style-type: none"> ○ Articulated and multi-tiered cradles should have the rated capacity displayed in each bay. • Always make sure that all materials are evenly distributed across the cradle.
Data Plates	<ul style="list-style-type: none"> • All suspended scaffolding should have legible data plates with the following information: <ul style="list-style-type: none"> ○ Serial number. ○ Type/model identification. ○ Name/identification mark of the manufacturer. ○ Rated capacity. ○ Size, maximum length, grade and construction of Flexible Steel Wire Rope (FSWR) (where applicable). ○ Reeving and power supply requirements (where applicable).

Hoists

Requirements for hoists which should be checked for include:

Item	Requirements
Protective Devices	<ul style="list-style-type: none"> • Most hoists should have built-in or independently mounted protection devices to act as an emergency brake in the event that the suspension rope is broken. • A double rope suspension scaffold does not need a protective device for each scaffold.
Load Limiter	<ul style="list-style-type: none"> • Electric hoist should be fitted with: <ul style="list-style-type: none"> ○ Load limiting device to stop the hoist damaging the suspension rope or toppling the suspension rig, if the scaffold becomes jammed. • Electrically powered suspension scaffold must be fitted with: <ul style="list-style-type: none"> ○ Load limiting device with a maximum setting of 1.25 x the rated capacity of the hoist or 125%.

Scaffolding hoists should be designed, manufactured and tested in accordance with the Australian Standard AS 1418.2 – Scaffolding Hoists.

Always make sure a purpose-made weatherproof cover is fitted to all scaffold hoists to prevent contamination of the working mechanisms.

Suspension and Secondary Ropes

It is important that all suspension and secondary ropes must meet the requirements of the scaffold. These include:

Item	Requirements
Rope Arrangement and Requirements	<ul style="list-style-type: none"> • Suspension and secondary ropes should be the correct size and construction for the hoist or protective device used. They should have a swaged and thimble eye at one end. • There should be at least 1m of spare rope when a climber-type scaffolding hoist is at its lowest point. Excess rope should be protected from damage by coiling and tying or by being placed around a rope winder. • At least 3 turns of rope should remain on the drum when a drum-type scaffolding hoist is at its lowest point. This will: <ul style="list-style-type: none"> ○ Prevent damage at the anchor point. ○ Reduce tension on the anchorage point on the drum. ○ Prevent the rope from disconnecting and the cradle falling. • The drum flange should extend 2 rope diameters beyond the built up rope on a fully-loaded drum-type scaffolding hoist. This will prevent the rope from jumping over the drum flange. • When replacing the FSWR on a climber hoist it is important that the same FSWR construction and size are used in accordance with manufacturer's instructions to help prevent: <ul style="list-style-type: none"> ○ The FSWR from being damaged as it runs over the sheaves. ○ The sheaves from destroying and/or severing the rope. ○ Total failure resulting in the platform dropping.
Rated Capacity of Suspension Rope	<p>The rope tension on a shackle supporting a suspension rope should be no more than 80% of the shackles rated capacity.</p> <ul style="list-style-type: none"> • The rope tension on a choked sling supporting a suspension rope should be no more than 40% of the slings rated capacity.
Secondary Wire	<p>Secondary wire ropes should be attached to the suspension rigging independent of the main suspension rope.</p>

Suspension Rigs

You should ensure that the suspension rig is adequate for the scaffold. Requirements you should check for include:

Item	Requirements
Suspension Rig	<ul style="list-style-type: none"> • Must remain rigid and stable under working conditions. • The design should take into account all forces and load (e.g. wind loads). • A reveal propped needle suspension rig: <ul style="list-style-type: none"> ○ Should have at least two rows of uprights fixed with ledgers and transoms as well as longitudinal, transverse and plan bracing systems. ○ Needles can be fixed onto or under the reveal props. ○ Close fitting U-heads may be used with rolled steel joists or universal beams.
Needle or Supporting Beam	<ul style="list-style-type: none"> • Should always be mounted with the greater vertical dimension. • The outboard end of a needle should never be lower than the inboard end. • A beam spanning between only two supports should always be horizontal.
Anchors	<ul style="list-style-type: none"> • If anchorage bolts are used they should be kept from loosening (e.g. with lock nuts). • Do not use friction or chemical insert anchors on needles. • Through bolts, props or bracket bolts are recommended for fixing the rig/needle in place.
Props	<ul style="list-style-type: none"> • If using props, they should be installed to the top of the needle and to the underside of the floor above. • You must make sure that the props are correctly fixed to stop any movement or dislodgement: <ul style="list-style-type: none"> ○ Have a competent person (such as an engineer) check that the floor is able to withstand the force of the props and scaffold.

Counterweights and Tracks and Trolleys

All counterweights, tracks and trolleys must meet the following requirements:

Item	Requirements
Counterweights	<ul style="list-style-type: none"> • Only use counterweights specially designed, manufactured and approved for the erection of suspended scaffolds. Make sure that the counterweight is made from a durable material where the weight of the counterweight will remain constant under different working conditions. • The counterweight should be secured directly on the needle or innermost support in such a way that they cannot be removed or displaced without the use of tools. This will help to prevent the counterweights from slipping from the scaffold or being removed by accident. • The mass of the counterweight in kilograms must be permanently on display on the counterweights.

Item	Requirements
Tracks and Trolleys	<ul style="list-style-type: none"> • Traversing tracks are hung beneath needles or supported by beams. The ends should be fitted with through bolted stops to stop trolleys running off the track. • The trolley supporting a suspension rope should have a rated capacity of at least 500 kg. • A spacer tie or spreader bar can be used to stop two trolleys from spreading (moving apart) while supporting a swing stage. • Trolleys supporting a double rope suspended scaffold should be rigidly connected with plan braced to stop twisting. • Ropes used for horizontal movement of a suspended scaffold should be a minimum 12mm diameter fibre rope.

3.1.1.3 Calculations for Suspended Scaffolds

Example: A suspended scaffold supported from a counterweighted cantilevered suspension rig is being erected.

The scaffold is made up of one (1) cradle supported from two (2) needles with one (1) suspension rope and one (1) scaffolding hoist per needle.

The Configuration is as Follows:	
Needles outboard	1.5m
Needles inboard	6m
Weight of counterweights	30kg
Length of rope	60m
Weight of rope	40kg per 100m
Rated capacity of hoist	800kg
Weight of scaffolding hoist motor	60kg
Stabilising weight	12kg

To find out the maximum rope tension use the following formula:

$$\text{Rope Tension} = (\text{HRC} \times 1.25) + \text{Rope Weight} + \text{Hoist Motor Weight} + \text{Stabilising Weight}$$

Where HRC = Hoist Rated Capacity.

Use the formula to determine the maximum rope tension for the scaffold:

Step	Calculations	Explanation
Step 1	$= 800 \times 1.25$ $= 1000$	Multiply the hoist rated capacity by 1.25
Step 2	$= 60 \div 100 = 0.6$ $= 0.6 \times 40$ $= 24\text{kg}$	Calculate the weight of the rope by dividing the length by 100 and multiplying it by the weight per 100m.
Step 3	$= 1000 + 24 + 60 + 12$ $= 1096\text{kg}$	Add the answers from 'Step 1' and 'Step 2' to the hoist motor weight and the stabilising weight.

Conclusion: Maximum rope tension is 1096kg.

NOTE: AS 1576 Clause 4.5 Load-Limiting Device states that electrically powered scaffolding hoists shall have a device to limit the lifting capacity of the hoist to a maximum 1.25 times the rating of such hoist. And Clause 4.7 Rope Tension states that rope tension for electrically powered scaffolding hoists is the summation of the load which is limited by the load limiting device, the gravitational load of the suspension rope and the tensioning weight.

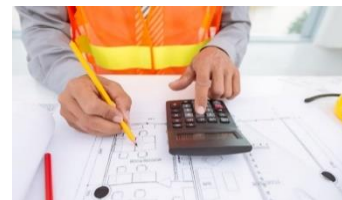

To calculate the number of counterweights needed at the inbound end of the needle use the following formula:

$$\text{Number of Counterweights} = \frac{(\text{Rope Tension} \times \text{Outboard} \div \text{Inboard}) \times \text{Safety Factor}}{\text{Mass of Counterweight}}$$

Using a safety factor of 3, use the formula to determine the number of counterweights needed at the inbound end of the scaffolding needle:

Step	Calculations	Explanation
Step 1	$= \frac{(1096 \times 1.5 \div 6) \times 3}{30}$	Insert the figures from the scaffolding configuration and previous calculation into the formula.
Step 2	$= 1096 \times 1.5 \div 6$ $= 274$	Complete the brackets in the top section of the fraction.
Step 3	$= 274 \times 3$ $= 822$	Multiply the answer by the safety factor provided.
Step 4	$= 822 \div 30$ $= 27.4$	Divide the answer by the mass (weight) of the counterweights.

Conclusion: 28 counterweights will be required.

To calculate the minimum guaranteed breaking load of the suspension rope, use the following formula:

$$\text{Minimum Breaking Load} = \text{Safety Factor} \times \text{Rated Capacity}$$

Using a safety factor of 10, use the formula to determine the minimum breaking load of the scaffold’s suspension rope:

Calculations	Explanation
= 10 x 800 = 8000kg	Insert the figures from the scaffolding configuration and previous calculation into the formula.

Conclusion: the minimum guaranteed breaking load of the scaffold’s suspension rope is 8000kg (8 tonnes).

3.1.2 Hung Scaffolds

Hung scaffolds come in 2 main types:

Fabricated Hung Scaffolds	These are purpose built temporary structures that are attached to a permanent structure (such as a building or transmission tower) to support a working platform for personnel, tools and materials.
Tube and Coupler Hung Scaffolds	These are constructed from tubes to create a scaffold that is designed specifically for the structure it is attached to, and the work to be carried out.

Hung scaffolds are usually positioned in a static location, but depending on the work being conducted, may be hung from girder trolleys or mobile suspension rigs so they have limited horizontal (sideways) movement. Hung scaffolds are not capable of being raised or lowered while in use.

Shown here is an example of a hung scaffold that is supported by steel beams. The supports shown in the example are tubes, however it is possible for a hung scaffold to be supported using beam clamps and chains or FSWR.

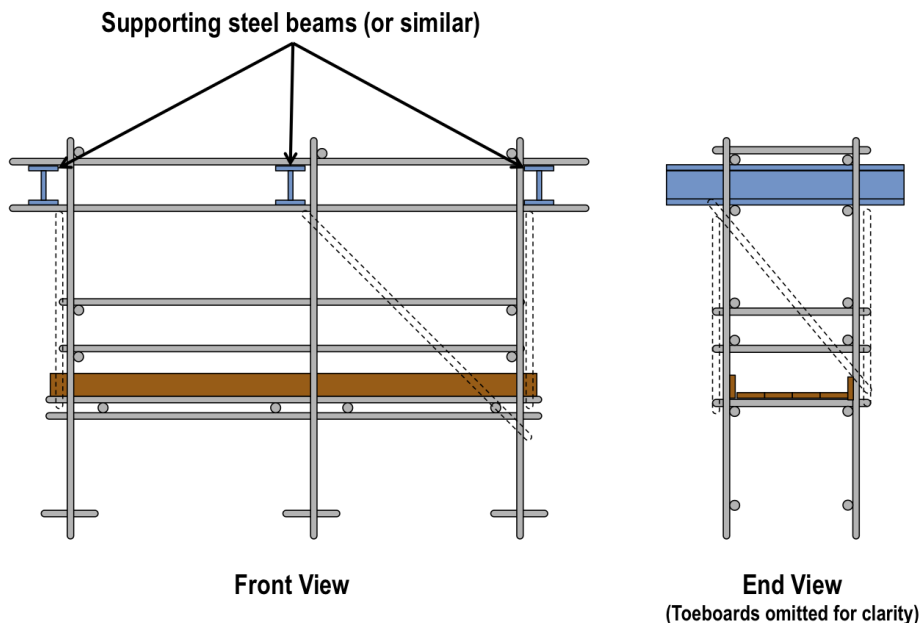

Hung scaffolds may also be erected with supports that pass through a supporting structure such as a grating or suspended concrete floor.

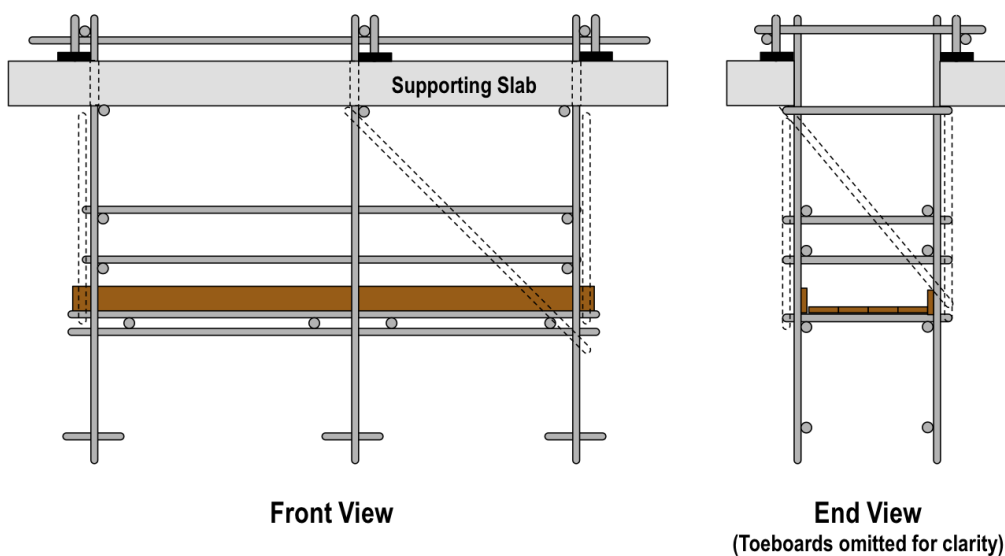



When erecting a hung scaffold **DO NOT:**

- Use open-ended hook rods.
- Extend its length by fixing scaffold tubes with end-to-end couplers.

The building or structure to which a hung scaffold is to be mounted must be able to support the scaffold as well as all loads placed upon it (e.g. dead loads, live loads, wind loads). The supporting structure should be assessed by a competent person before the hung scaffold is erected.

Structural changes made to the hung scaffold should be recorded on a design plan and reviewed by a competent person.

3.1.2.1 Hung Scaffold Requirements

All hung scaffolds must meet some basic safety and construction requirements. The following table outlines the minimum requirements for hung scaffolds:

Item	Requirements
Working Platform	<ul style="list-style-type: none"> • The platform of a hung scaffold should be evenly decked, slip resistant and free from trip hazards. It should be secured safely to prevent movement. • Generally, the platform should be horizontal with an allowable slope of 3° in all directions, although sloping platforms may be designed for certain purposes. The slope of a working platform should be no more than 7° (1:8).
Edge Protection	<ul style="list-style-type: none"> • Required where a person could fall more than 2m. • Scaffold tube, purpose designed component or hardwood may be used for a guardrail. Fibre rope, flexible steel wire rope (FSWR) and chain must never be used as a guardrail. • Guardrail should be positioned between 900mm and 1100mm from the work platform surface. • Toeboards must extend at least 150mm above the surface of the working platform. • Midrails, infill, brick guards or mesh must be positioned between the toeboard and the guardrail.

Item	Requirements
Access	<ul style="list-style-type: none"> • Methods to access a hung scaffold when erecting or dismantling the scaffold include: <ul style="list-style-type: none"> ○ The use of fittings on the standard. ○ Installing temporary platforms. ○ Using an elevating work platform. ○ Using a ladder. • Single industrial grade ladders may be used to access working platforms. Domestic grade or extension ladders must not be used. • Ladder access should be fixed in a position between 6:1 and 4:1 vertical to horizontal. • The minimum height that a portable access ladder must extend above the landing is 900mm. • Access ramps may have a slope of up to 20° (1:3) as long as they are cleated to prevent slip hazards. Cleats should be 50 mm wide and 25mm thick and fixed at intervals of 450mm. • Considerations that should be given to the installation of ladders on hung scaffolds include: <ul style="list-style-type: none"> ○ The angle of the ladder. ○ The extension above the landing. ○ The type of ladder. ○ The security of the ladder. ○ Fall prevention or fall arrest systems.
Supports	<ul style="list-style-type: none"> • A hung scaffold can be fixed to a supporting structure in a number of ways including rigid supports or slings (chain and FSWR) and shackles. • Trolleys, beam clamps and shackles used to support a hung scaffold should have a rated capacity of at least 500 kg. • Flexible Steel Wire Rope (FSWR) must have a minimum construction of 6x24 and be at least 11 mm in diameter when used to support a hung scaffold. • Chain must be at least Grade T and not less than 8mm in diameter when used to support a hung scaffold. • The maximum load placed on FSWR or chain must not be more than 1/6 of its minimum breaking strain. • The Rated Capacity of FSWR can be estimated using the formula: <ul style="list-style-type: none"> ○ Diameter squared x 7.5. • Beam chaffers, half rounds and split tubes can be used to protect a Flexible Steel Wire Rope (FSWR) from damage when it is placed around the sharp edges of a beam. • Scaffold tubes being used as standards for a hung scaffold must be in single lengths. • Shackle pins should be moused or a locking device used to stop them from unwinding. • Do not use speed thread or multi-start thread coupler bolts for fixing

	<p>hung standards.</p> <ul style="list-style-type: none"> • Prefabricated modular standards with suitable connections may be used to transfer the applicable tension forces. • Couplers should be fixed on a ledger on either side of the eye of a sling to stop it sliding. • Check couplers should be located directly underneath the lowest ledgers and directly over the suspension points when using scaffolding tubes for hung standards.
<p>Positioning</p>	<ul style="list-style-type: none"> • Trolleys should have a rated capacity greater than the total load they are to support. • Rigid tie bars and plan bracing may be used to prevent girder trolleys from moving out of alignment. This will help the standards to remain vertical. • Girders are required to have through-bolted stops to prevent the trolley from overrunning or running off the end of the girder.

3.1.2.2 Calculations for Hung Scaffolds

Example: A heavy duty hung scaffold is being erected. It will be supported by steel beams and will be two (2) bays in length.

The scaffold will be made up of the following components:

Hung Scaffold Equipment List				
Component	Length (m)	Weight (kgs)	Quantity	Composite Weight
Timber planks	3.2	21.5	6	129
Timber planks	2.5	16.5	5	82.5
Timber planks	1.6	11.0	2	22
Timber planks	1.2	8.0	2	16
Ladder	4.0	20.0	1	20
Tubes	0.4	1.6	6	9.6
Tubes	0.8	3.2	6	19.2
Tubes	1.2	4.8	4	19.2
Tubes	1.5	6.0	2	12
Tubes	1.6	6.4	14	89.6
Tubes	2.0	8.0	2	16
Tubes	3.2	12.8	6	76.8
90 degree right angle check couplers		1.0	98	98
90 degree right angle couplers		1.0	10	10
Swivel couplers		1.0	1	1
Putlog couplers		1.0	18	18
Putlog couplers (for kickboards/access)		1.0	20	20
FSWR single sling	4.2	8.4	2	16.8
Lashing wire	98.0	0.1	14	1.4
Total weight				677.1
Total weight (rounded up to the nearest kg)				678kg

To determine the total weight of each of the scaffold components, use the following formula:

Weight (kgs) x Quantity = Composite Weight

Use the formula to calculate the composite weight of each component:

Calculations	Explanation
$21.5 \times 6 = 129\text{kg}$	Multiply the weight of each component by the quantity.

Conclusion: The composite weight of the 3.2m timber planks = 129kgs.

To determine the total weight of the scaffold equipment, add the composite weight of all the components together:

Composite Weight + Composite Weight = Total Weight

Use the formula to determine the total weight of the scaffold equipment using the hung scaffolding equipment list table:

Calculations	Explanation
$129 + 82.5 + 22 + 16 + 20 + 9.6 + 19.2 + 19.2 + 12 + 89.6 + 16 + 76.8 + 98 + 10 + 1 + 18 + 20 + 16.8 + 1.4 = 677.1\text{kg}$	Add the composite weight of each scaffold component together.

Conclusion: total weight = 678kg (rounded up to the nearest kg).

Now that you have determined the total weight of the scaffold components, you can calculate the design load.

First, you need to work out the live load using the following formula:

Heavy Duty x Number of Bays = Live Load

Use the formula to determine the live load of the scaffold:

Calculations	Explanation
= 675 x 2 = 1350kgs	Insert the heavy duty scaffold weight and multiply by two (2) for each bay.

Conclusion: live load = 1350kg.

Now that you have identified the live load you can calculate the design load using the following formula:

Live Load + Dead Load = Design Load

Where dead load = total weight.

Use the formula to determine the design load of the scaffold:

Calculations	Explanation
= 1350 + 678 = 2028kg	Add the dead load (total weight) and the live load together.

Conclusion: the design load of the hung scaffold = 2028kg.

3.1.3 Installing a Materials Hoist

Materials hoists run up and down the outside of a tower using a wire rope hoisting system for raising and lowering the platform.

Under no circumstance can these hoists be used to carry passengers.

Only certificated personnel carrying out erection, dismantling and maintenance can ride on the platform of a materials-only hoist.

The hoist must be set up on solid timber packing.



Clear signage should indicate that no persons are allowed to ride on the materials hoist platform.

Always refer to the manufacturer's operating manual for directions on how to set up and operate the materials hoist safely.



When setting up near a trench, the distance between the base of the tower and the edge of the trench must be greater than the depth of the trench (e.g. 3m away from a 2m trench).

At the base of the tower a handrail, with a moveable or sliding rail to allow access to the platform, must be set back at least 600mm from the working platform to stop people from leaning over and being hit by the moving platform.

A landing gate is required to stop materials or people from entering the path of the hoist. The gate must be a minimum of 1.8m high.

On the floors above, a handrail must be placed 600mm from the edge of floors to prevent people falling off.

There must be an overhead guard to protect the operator from falling objects.

The hoist must not be set up in front of any access way to a building (such as a doorway or a window) unless it is blocked off to stop people leaning out and being hit by the passing platform.

The gap between the platform floor and the building floor must be no less than 25mm and no more than 150mm. If the gap is greater than 100mm a fold down flap or bridging flap should be provided.

Ties can be used to attach the hoist tower to the supporting structure. Using ties will help to ensure that the tower is maintained in a fixed position and prevent distortion and the sideways movement of the tower.



The tower must be guyed or tied every 6m. Check the manufacturer's specifications to determine the maximum height you can stand the hoist tower above the top tie.

Guy ropes must be at least 9mm in diameter for hoists to 500kg capacity and at least 12mm for more than 500kg (and 6 x 19 construction).



The minimum over-run distance between the hoist rope attachment and the head sheave is 1.5m.

Once the hoist is completed check that it complies with the installation specifications. You also need to make sure you install signage displaying the rated capacity of the hoist.

3.1.4 General Scaffold Safety Requirements



Any incomplete or unfinished scaffolds need to have all access removed if being left unattended overnight.

You must also ensure that adequate isolation methods or barricading is in place to prevent unauthorised access.

Signage and/or tags should be added to the scaffold to indicate that the scaffold is incomplete and must not be used.

Once a scaffold is fully completed and deemed safe to use a handover certificate must be presented. This handover certificate must be correctly completed once an inspection has taken place, and must be filled out by a competent person.

3.1.5 Ties

Ties are used to maintain the stability of the scaffold by preventing unwanted inward or outward movement.

There are five (5) basic configurations that can be used to secure the tie to the structure or equipment being secured:

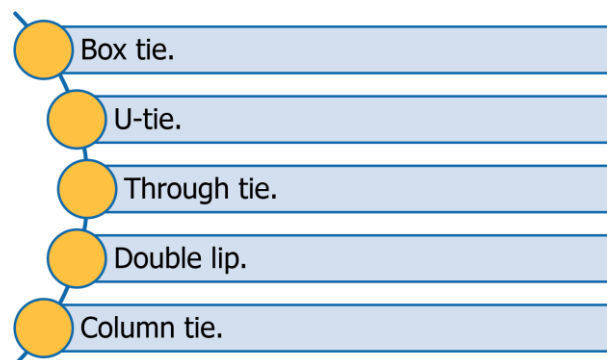

The method you select will be determined by the structure or equipment the ties are being fixed to.

3.1.5.1 Box Tie

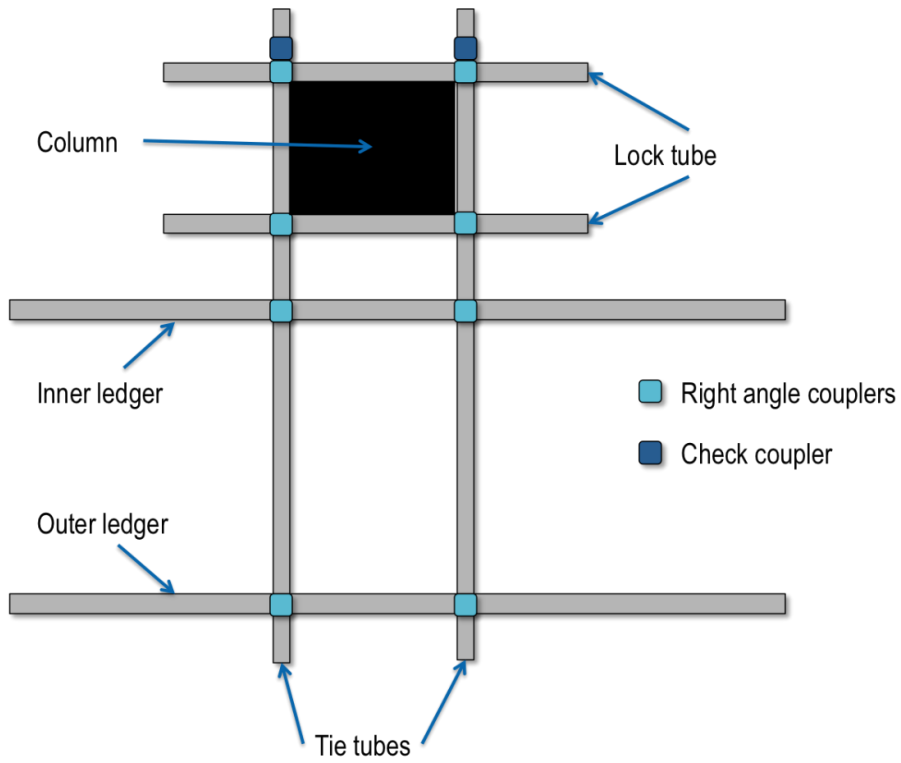

3.1.5.2 U-tie

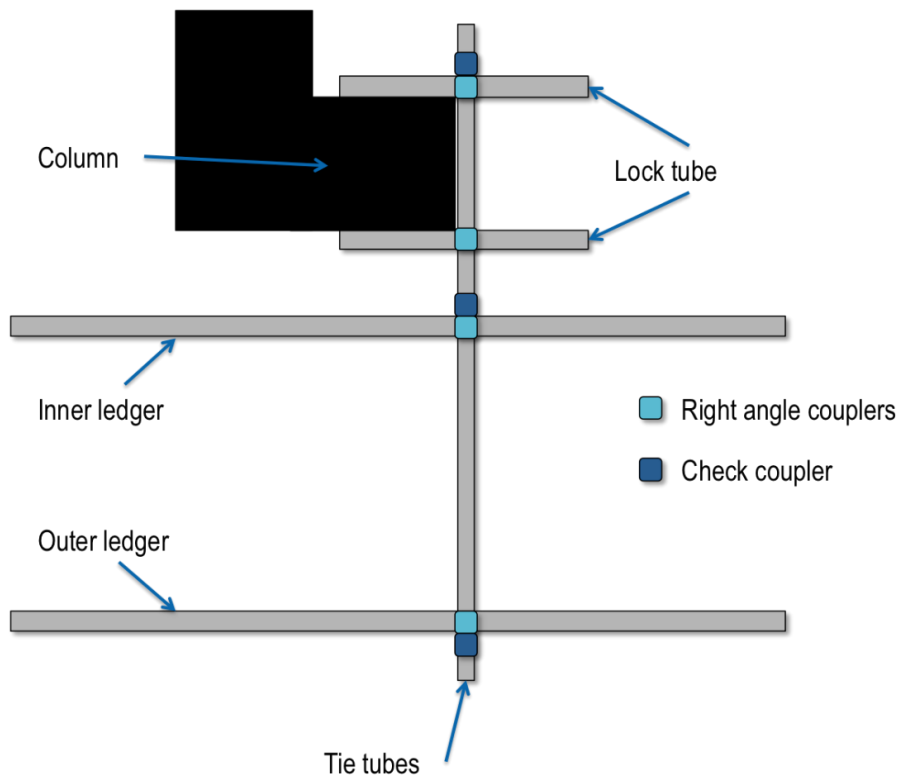

3.1.5.3 Through Tie

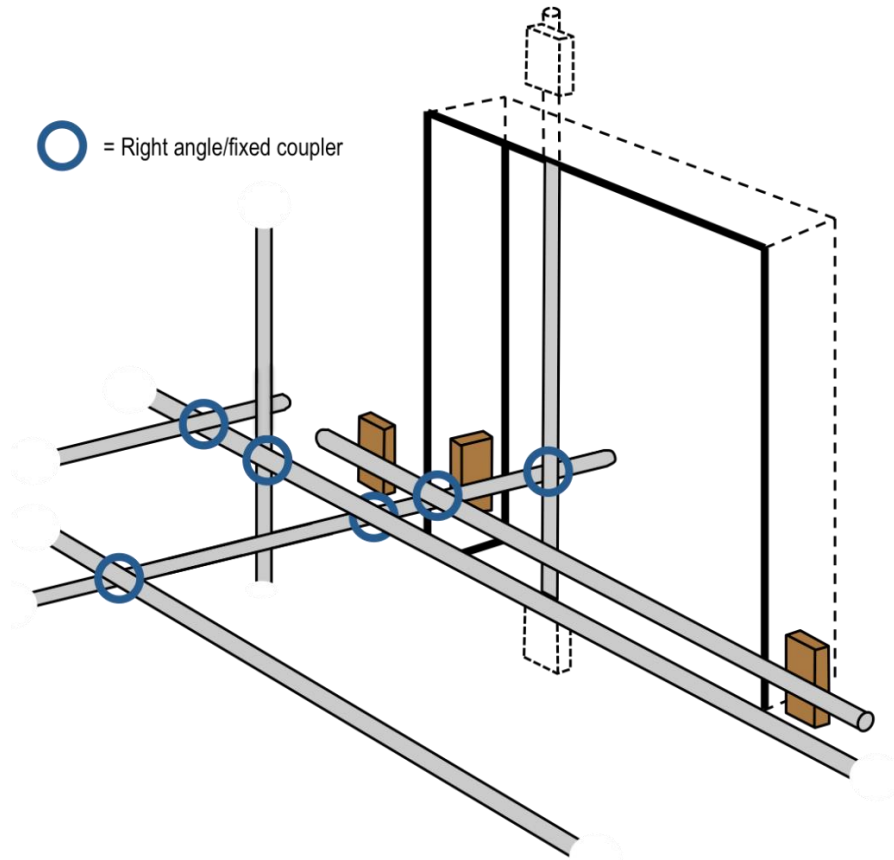

3.1.5.4 Double Lip

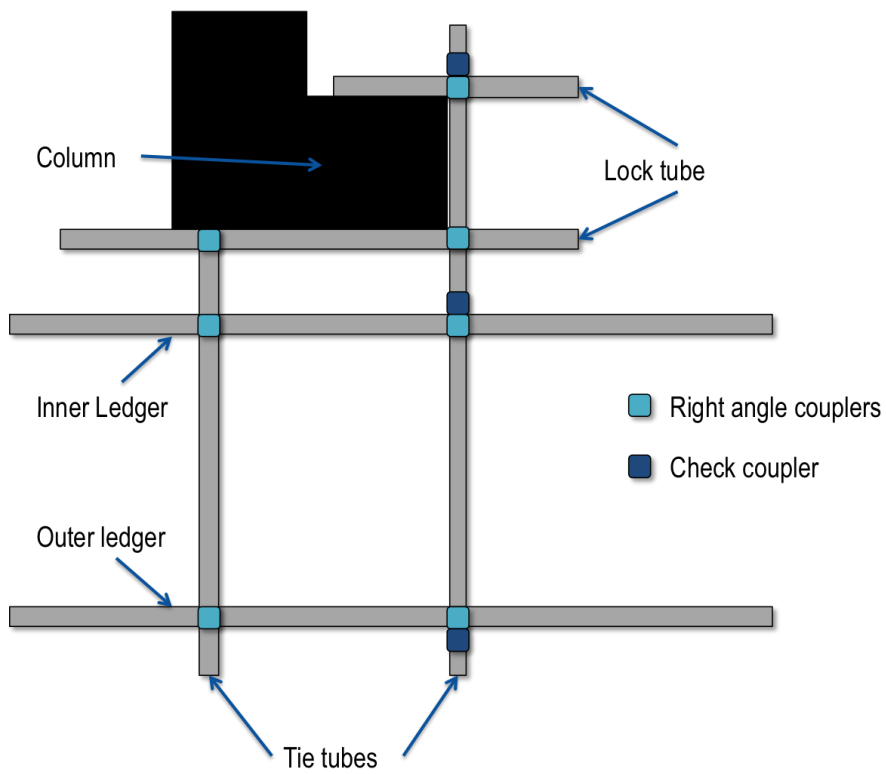

3.1.5.5 Column Tie

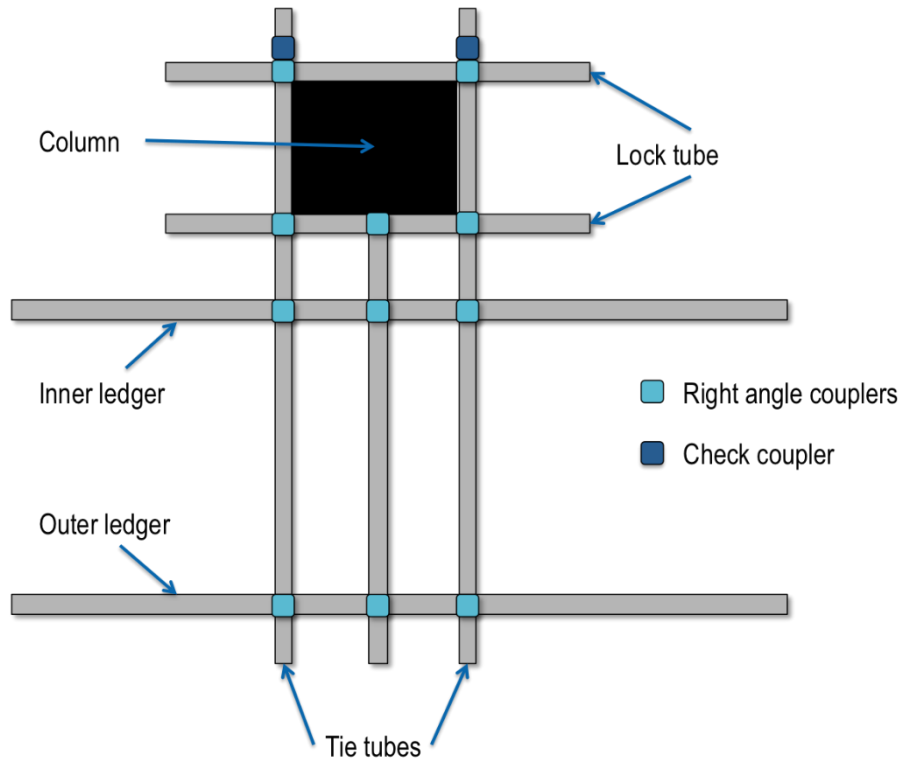

3.1.6 Work Safely at Heights



Working at heights includes any situation where a worker, or other nearby person, is exposed to a risk of falling (from one level to another) that is likely to cause injury to the worker or person.

All work at heights should include the use of safety equipment to prevent hazards such as personnel and materials falling from a height.

Stay in effective communication with other workers. All activities should be coordinated to ensure safety for all personnel and the effective completion of the scaffolding tasks.

DO NOT ever work on the open framework of a scaffold without fall protection systems in place. Guardrails and midrails should be installed on working platforms as soon as possible during the erection and dismantling of scaffolds.

When working at heights:

- Make sure that the work area is kept clean and tidy. Rubbish should be removed regularly in a safe manner. Do not throw rubbish down from the work area to the ground.
- Keep access ways clear of materials, tools and equipment.
- Pass, receive and position components safely and confidently.



If you are planning on using a fall arrest harness you will need to consider the following:

- The anchorage point strength.
- The maximum fall distance.
- If there are any sharp edges nearby or obstructions below.
- If there is safe access to the anchor point.
- If rescue options are in place.



When using handlines you should keep your back straight, your knees slightly bent and your feet placed firmly on a ledger. Use the standard as an anchor for your body.

The area below the work should be barricaded or fenced off to prevent unauthorised access by other workers or the general public. Where this is not possible, overhead protection decks such as temporary gantries, covered ways, cantilevered catch platforms, perimeter safety screens or debris/safety nets may need to be installed.

Check access from the ground to the work area (where applicable) to make sure it is safe, free of obstructions and meets all safety and work requirements.

All hand tools should be securely stowed on a belt to maintain the safety of all personnel.

3.1.6.1 Monitor Work Area and Equipment

You should regularly monitor the work area for changing conditions or new potential hazards. Periodically check all equipment during work to ensure that it remains safe, effective and undamaged.

Monitor the work area and equipment to make sure that:

- Safety equipment remains effective and has not been damaged.
- Fall protection equipment is in place and adjusted appropriately to cater for movement during work.
- Scaffold components and fall barriers are in place during work.
- Existing hazard controls are monitored and modified in relation to changing work practices or site conditions.
- New hazards are identified and appropriate hazard controls are implemented to deal with them.



Make sure that any excess materials are removed from the work platform area as soon as it is possible to do so. This will help to:

- Reduce the risk of slips and trips.
- Reduce the risk of materials falling from heights.
- Prevent overloading of the platform.

Weather Conditions

It is important that you remain aware of changing weather conditions including strong winds or rain. These may create a hazard on site, risking health and safety of workers. You may need to adjust your work methods and techniques if hazardous weather conditions arise, or stop work altogether if necessary.



Sudden strong gusts of wind may cause workers to lose their balance or cause materials or equipment to be swept over the edge of the work area. Whereas rain may cause the surface of the work area to become slippery.

Under no circumstances should suspended scaffolds be used in extremely windy conditions.

3.1.7 Communications

Make sure you select the most appropriate communication equipment and methods to co-ordinate the scaffolding task.

This communication could be between you and plant operators, or other members of the scaffold team.



Communications need to be clear especially between workers who are on different levels of the scaffold during the erection process.

It is important that you are able to communicate effectively, this will allow you to:

- Coordinate the movement of scaffold components.
- Work to the schedule or plan during the erection process.
- Ensure the stability of the scaffold and the safety of the workers in the area.

3.2 Recording Scaffold Erection and Modification

After erection or modification of scaffold there are certain checks and documentation to be completed. This is to make sure that the scaffold meets requirements and aligns with the details in the original scaffold plan.



3.2.1 Inspection and Documenting Scaffolds Erection

Once the scaffold has been erected it will need to be inspected by a competent person for the following:

- Stability and condition of structure.
- Standards secure, plumb, correctly joined and spaced (where relevant).
- Ledgers secure, level, correctly joined and spaced (where relevant).
- Transoms/putlogs secure, level, correctly joined and spaced (where relevant).
- Bracing and ties in correct position and properly fixed (where relevant).
- Sufficient and safe access to all working platforms.



- Platforms positioned and secured correctly. Correct number and dimensions of platforms for duty.
- Edge protection correctly installed.
- Sheeting/screens/shutters correctly installed (where relevant).
- Scaffold matches structural plan.

Once a scaffold erection, inspection or modification is completed an inspection record needs to be placed on the scaffold.

The inspection record needs to include the following details:

Record Detail	Explanation
Location	Unit/plant number followed by area of plant.
Ref. No.	Work Order number.
Date Erected	Date the erection of the scaffold was complete.
Requested By	This should be the Team leader/Plant Area Coordinator etc., requesting the scaffold. (This may be on the Work Order).
Built By	This is the company who built the scaffold.
Name of Competent Person	Print the name of the competent person/certified scaffolder.
Signature	Signature of competent person/certified scaffolder.

Light Duty 225kg	As per AS/NZS 4576.
Medium Duty 450kg	
Heavy Duty 675kg	

3.2.2 Modifying or Inspecting a Scaffold

Where practicable, the licensed person who erected the scaffold, and whose name appears on the inspection record, is to be the person to perform scaffold modifications and inspections.



Prior to modifying scaffold:

- Remove the inspection record.
- Replace with a notification inspection record detailing the date and time of the modification or inspection, the name of the person performing the modification or inspection and the reason for the alteration where relevant.

Shown here is an example of an inspection record system of cards:

Inspection Record Card Holder	Inspection Record Front	Inspection Record Back																																				
 <p data-bbox="231 943 472 965">This inspection record is an example only</p>	<p data-bbox="654 271 940 974">Safe Work Scaffolding SCAFFOLD RELEASED FOR ACCESS LOCATION <input type="text"/> REF. NO. <input type="text"/> DATE ERECTED <input type="text"/> REQUESTED BY SIGNATURE <input type="text"/> PRINT <input type="text"/> COMPETENT PERSON SIGNATURE <input type="text"/> PRINT <input type="text"/> DUTY <input type="text"/> NOTES <input type="text"/></p> <p data-bbox="687 943 906 965">This inspection record is an example only</p>	<p data-bbox="1101 271 1386 974">Safe Work Scaffolding ALL SCAFFOLDING COMPONENTS AND STRUCTURES MUST BE INSPECTED BY A COMPETENT PERSON BEFORE EACH WORKSHIFT AND AFTER ANY INCIDENT WHICH COULD ALTER THE STRUCTURAL INTEGRITY OF THIS SCAFFOLD.</p> <table border="1" data-bbox="1118 521 1369 943"><thead><tr><th colspan="2">INSPECTION RECORD</th></tr><tr><th>DATE</th><th>COMPETENT PERSON</th></tr></thead><tbody><tr><td> </td><td> </td></tr><tr><td> </td><td> </td></tr><tr><td> </td><td> </td></tr><tr><td> </td><td> </td></tr><tr><td> </td><td> </td></tr><tr><td> </td><td> </td></tr><tr><td> </td><td> </td></tr><tr><td> </td><td> </td></tr><tr><td> </td><td> </td></tr><tr><td> </td><td> </td></tr><tr><td> </td><td> </td></tr><tr><td> </td><td> </td></tr><tr><td> </td><td> </td></tr><tr><td> </td><td> </td></tr><tr><td> </td><td> </td></tr><tr><td> </td><td> </td></tr></tbody></table> <p data-bbox="1134 943 1355 965">This inspection record is an example only</p>	INSPECTION RECORD		DATE	COMPETENT PERSON																																
INSPECTION RECORD																																						
DATE	COMPETENT PERSON																																					

3.2.3 Completing a Handover Certificate

As the licensed person who erected the scaffold, you will need to complete a handover certificate and sign off tag when the job is complete.

It should contain the following information:

- The name of the client that the work has been done for.
- Address of the worksite where the tasks were completed.
- The location of the scaffold in the worksite.
- The type of scaffold that was erected (e.g. modular, mobile).
- The height and length of the scaffold.
- The number of lifts and bays in the scaffold.
- The duty category of the scaffold (e.g. light, medium, heavy, special).
- The type of access available (e.g. ladder, ramp, stairway).
- Design reference number.
- Date and time of handover.
- Name and signature of the responsible person.



An example of a handover certificate can be found in **Appendix B**.

3.3 Dismantle Scaffold and Scaffold Equipment

When work on the scaffolding has been completed it is time to dismantle the structure and any associated equipment. You need to do this safely and methodically and maintain good communication with other personnel on site while doing so.



3.3.1 Procedures for Safe Dismantling of Scaffolding

Always follow the manufacturer's instructions when disassembling equipment to ensure the safety of all personnel in the area, to maintain stability during the process and to prevent any damage to the plant and equipment.

Dismantle the scaffold according to the correct procedures.

- Work safely at heights utilising safety equipment such as fall arrest systems (e.g. harness and lanyard).
- Clear the platforms of all equipment and loose material.
- Maintain clear communication with other personnel to ensure everyone knows what they are supposed to be doing.
- Always work methodically and follow site procedures to avoid any unplanned collapse of plant and equipment. Unplanned collapse can result in serious injuries to personnel and damage to equipment and materials.



Once they are no longer needed, safety systems such as static lines, fall-arrest harnesses and safety nets should be dismantled according to the correct sequence and procedures, then removed from the work area.

3.4 Incidents and Emergency Response



Emergencies can happen quickly and without warning when work is being done at heights.

If all necessary precautions, hazard control measures and safety equipment have been used then the risk of serious consequences is reduced.

However, you should always be prepared to take action in an emergency situation, even if that action is as simple as calling for help.

3.4.1 What is an Incident?

An incident is:

- An accident resulting in personal injury or damage to property.
- A near miss or dangerous occurrence which does not cause injury but may pose an immediate and significant risk to persons or property, and needs to be reported so that action can be taken to prevent recurrence.



All incidents **MUST** be reported!

3.4.1.1 Responding to an Incident

If an unsafe incident or event occurs during rigging operations you should:

- 1** Stop work immediately and if it is safe to do so.
- 2** Assess the problem.
- 3** Find a solution if possible (resolve the problem).
- 4** If needed, seek advice and assistance.
- 5** Report the incident according to procedures.

3.4.2 Workplace Emergencies



Site emergencies may include:

- Fire (electrical, chemical, gas, mechanical, paper, wood or natural).
- Gas leak.
- Toxic and/or flammable vapours emission.
- Vehicle/machine accident.
- Chemical spill.
- Injury to personnel.
- Structural collapse.

3.4.2.1 General Emergency Response

In the case of an emergency:

1. Remain calm.
2. Raise the alarm with your supervisor, safety officer, emergency services (dial 000) and any other people at the workplace.
3. You need to tell people:
 - a) That there is an emergency.
 - b) What the emergency is.
 - c) Any unsafe areas that need to be avoided.
4. Evacuate if necessary (refer to site emergency plans).



3.4.2.2 General First Aid



First Aid kits must be supplied by your employer.

The location of these kits should be clearly marked with signage.

In the case of an emergency where somebody requires first aid, notify your supervisor or first aid officer and they will take action.

3.4.3 Incidents Relating to the Use of Fall-Arrest Systems

If a worker who is using an individual fall-arrest system falls from an edge, the system may act as a pendulum.

This may result in the worker hitting the ground (called 'swing down') or swinging back into the building or structure (called 'swing back').

These situations may also be referred to as 'the pendulum effect'.

Swing down can occur if the lanyard slides back along the perimeter edge of the roof as a worker falls, until it is vertical.

When this happens, the worker may hit the ground (or lower level), or the lanyard may break from being dragged across the edge of the roof.



3.4.3.1 Suspension Trauma



Suspension trauma can occur with a fall-arrest system when a person has an arrested fall and is suspended in an upright, vertical position with the harness straps causing pressure on the leg veins.

The lower legs' capacity to store large amounts of blood reduces the return of blood to the heart, slowing the heart rate, which can cause the person to faint.

This may lead to renal failure and eventually death, depending on a person's susceptibility. This condition may be worsened by heat and dehydration.

3.4.3.2 Preventing Suspension Trauma

The following techniques can be used to help prevent suspension trauma in a person who is hanging in a fall-arrest harness:

- Never work alone when using a harness as fall protection.
- Wherever possible use a fall-arrest harness that allows the legs to be kept horizontal.
- If possible, keep the time a worker spends in suspension after a fall limited to less than five minutes. This can be achieved by providing foothold straps or a way of placing weight on the legs.



If you find yourself in a situation where you are suspended in a fall-arrest harness after a fall attempt the following action:

1. Move your legs in the harness and push against any footholds to relieve pressure on your upper legs.
2. Move your legs as high as possible and tilt back so that you become as horizontal as possible.

The quick rescue of a person suspended in a full body harness, as soon as possible, is vital.

For this reason, workers should be capable of conducting a rescue of a fallen worker and be familiar with onsite rescue equipment and procedures.

If a worker has fallen and is hanging suspended in a safety harness for a prolonged period of time (5 to 30 minutes) it is absolutely vital that first aid procedures are implemented as quickly as possible.

3.4.3.3 First Aid for Suspension Trauma

In accordance with Australian Resuscitation Council (ARC) guideline 9.1.5, first aid management of suspension trauma should be carried out as follows:

1. Call for an ambulance (dial 000 or 112).
2. If unconscious, manage the victim according to basic life support principles. If conscious, rest the victim in a comfortable position, ideally lying down, and provide reassurance.
3. Loosen or remove the harness.
4. Administer oxygen if available.
5. Look for and manage associated injuries in the victim, especially if they have fallen or been electrocuted.
6. Monitor the signs of life at frequent intervals.



Remember, care of the airway takes precedence over any injury.

3.4.4 Report All Hazards, Incidents and Injuries



Depending on the nature and severity of the situation you may need to report to:

- Your supervisor.
- Emergency services (e.g. police, ambulance, fire brigade and emergency rescue).
- WHS regulatory authority (e.g. WorkSafe, WorkCover).

Ask your WHS representative or supervisor at the site office for the relevant forms and procedures for reporting hazards, incidents and injuries.

Review Questions

3.5 Conclude Scaffolding Operations

Once the scaffolding task has been completed you will need to carry out any other tasks as required by site procedures.

This may include:

- 1 Tidying the work area and removing rubbish or materials from the site.
- 2 Inspecting scaffolding and associated equipment for defects.
- 3 Isolating defective equipment in accordance with procedures and recording and reporting defects.
- 4 Removing hazard control measures.

3.5.1 Tidy the Work Area

Once the work has been completed you need to clean up the work area. Remove any leftover materials and debris created by the task as soon as practicable.



These can cause a tripping hazard for personnel.

Dispose of any debris properly without impacting negatively on the environment.

Divide up recycling and other waste materials for correct removal and processing.

3.5.2 Inspect and Store All Scaffolding Equipment



All equipment needs to be inspected once all scaffolding operations have been completed. Check for any damage that may have occurred while the equipment was in use. The manufacturer's instructions may have inspection checklists relating to different types of equipment that should be referred to.

It is important that you record inspections, services, faults and repairs in the relevant documentation as this information may be reviewed as evidence in incident and accident investigation.

Make sure that you clean the equipment if necessary and that all scaffolding equipment and parts are stored correctly in accordance with site procedures.

3.5.2.1 Isolate Faulty Equipment and Report Defects

Any defective equipment needs to be properly isolated and removed from service to prevent anybody from accidentally using it.

Standard procedures for isolating equipment and recording and reporting defects need to be followed.



3.5.2.2 Storing Tools and Equipment

Once all scaffolding equipment has been inspected for faults, it should be stored appropriately.

Each workplace will have systems in place for the storage of tools and equipment. You can find these in any relevant workplace policies and procedures.



Your induction to the work site should include the specific storage procedures you need to follow. If you do not know how to store scaffolding equipment speak to your supervisor or manager for information and instructions.

3.5.3 Remove Hazard Control Measures

Any control hazards that are no longer required need to be removed from the work area and stored according to procedures.

Inform any relevant personnel that the work area has been returned to normal conditions and that your tasks have been completed.



Appendix A –Work Method Statement

WMS Name:	WMS Created By:	Date of Creation:
WMS Summary:		Last Reviewed Date:

Company/Contractor Details:	Project Details:
Name:	Client:
ABN:	Contact Name:
Address:	Site Address:
Contact Number:	Contact Number:
Email:	Start Date:

How to complete this WMS:

- 1. CONSULT:** Consult with all persons who will be involved in the completion of the work.
- 2. LIST:** List each of the steps in the task work being done.
- 3. IDENTIFY:** Describe the health and safety hazards and risks arising from each step in the work.
- 4. RISK ASSESSMENT:** Review the level of risk associated with each hazard listed.
- 5. CONTROL:** Describe how the risks will be controlled, and describe what hazard control measures will be put in place.
- 6. RESPONSIBILITY:** Allocate a person to be responsible for the hazard control measure.
- 7. REVIEW:** Review the effectiveness of the control measures and apply further hazard control measures as required.

<p>Training/Qualifications Required To Carry Out Work:</p> <p>Are All Workers Adequately Trained And Qualified?</p> <p>Yes / No</p>	<p>PPE Required To Carry Out Work:</p>
<p>Legislation, Australian Standards & Codes Of Practice Relevant To Work (Where Applicable):</p>	<p>Equipment Required To Carry Out Work:</p>
<p>Environmental Statement:</p>	<p>Safety Checks Required Prior To Commencement Of Work:</p>
<p>Coordination With Other Trades:</p>	<p>Permits Required For Commencement Of Work:</p> <p>Have These Permits Been Acquired?</p> <p>Yes / No</p>

Risk Analysis Matrix

Use this table to determine the level of risk associated with an identified hazard.

	Consequence				
Likelihood	1. Insignificant	2. Minor First Aid Required	3. Moderate Medical Attention and Time Off Work	4. Major Long Term Illness or Serious Injury	5. Catastrophic Kill or Cause Permanent Disability or Illness
1. Rare	Low	Low	Moderate	Moderate	Moderate
2. Unlikely	Low	Low	Moderate	Moderate	High
3. Possible	Low	Moderate	High	High	Extreme
4. Likely	Moderate	Moderate	High	High	Extreme
5. Almost Certain	Moderate	High	High	Extreme	Extreme

Risk Level	Action
Extreme	This is an unacceptable risk level. The task, process or activity must not proceed.
High	This is an unacceptable risk level. The proposed activity can only proceed, provided that: <ol style="list-style-type: none"> 1. The risk level has been reduced to as low as reasonably practicable using the hierarchy of risk controls. 2. The risk controls must include those identified in legislation, Australian Standards, Codes of Practice etc. 3. The risk assessment has been reviewed and approved by the Supervisor. 4. A Safe Working Procedure or Work Method Statement has been prepared. The supervisor must review and document the effectiveness of the implemented risk controls.
Moderate	This is an unacceptable risk level. The proposed activity can only proceed, provided that: <ol style="list-style-type: none"> 1. The risk level has been reduced to as low as reasonably practicable using the hierarchy of risk controls. 2. The risk assessment has been reviewed and approved by the Supervisor. 3. A Safe Working Procedure or Work Method Statement has been prepared.
Low	The proposed task or process needs to be managed by documented routine procedures, which must include application of the hierarchy of controls.

Work Method Statement

Work Step	Associated/Identified Hazards	Risk Level	Hazard Controls	Revised Risk Level	Person Responsible
Work your way through each step in the work process, giving a brief description of what is required at each stage.	What hazards can be identified for this step?	What is the risk level?	What hazards controls will be put into place to deal with the identified hazards for this step?	Has the risk been reduced?	Who is responsible for carrying out the work and maintaining the hazard controls?

Work Step	Associated/Identified Hazards	Risk Level	Hazard Controls	Revised Risk Level	Person Responsible
Work your way through each step in the work process, giving a brief description of what is required at each stage.	What hazards can be identified for this step?	What is the risk level?	What hazards controls will be put into place to deal with the identified hazards for this step?	Has the risk been reduced?	Who is responsible for carrying out the work and maintaining the hazard controls?

Personnel Signoff

All personnel required to carry out this task need to be listed below.

By signing this WMS, each person declares that they have carefully read the WMS and that they understand their responsibilities and requirements to complete the work.

Name (please print)	Position / Qualification	Signature	Date

Senior Management Signoff

Does this WMS meet the necessary safety requirements? Yes / No

Does this WMS require review? Yes / No Review Date:

Additional Comments:			
----------------------	--	--	--

Name:	Position:	Signature:	Date:
-------	-----------	------------	-------

Appendix B – Handover Certificate

Handover Certificate		Handover Date:			
		Handover Time:			
Client Name:		Contact Name:			
Worksite Address:		Scaffold Location On Site:			
Type Of Scaffold:					
Duty Category (Please Circle)	Light	Medium	Heavy	Special	
Number Of Lifts:			Height Of Scaffold:		
Number Of Bays:			Length Of Scaffold:		
Type Of Access:			Design Reference Number:		
NOTES:					
Name Of Person Responsible:					
Signature Of Person Responsible:					