



Intermediate Scaffolding Learner Guide

High Risk Work License

**CPCCLSF3001 Licence to Erect, Alter and Dismantle Scaffolding
Intermediate Level**

Learner Guide

Course Induction

You are doing this course with National Courses Pty Ltd (RTO 41072). We trade as:



1) Identification (ID)

You must complete the state body official ID document and requirements.

2) Student Handbook

The Student Handbook was sent with your booking confirmation email.

The student handbook is an important document that explains our processes and systems and includes the following information:

- **Your rights & responsibilities**
- **Complaints, appeals & feedback**
- **Code of conduct**
- **What happens if you are caught cheating**
- **Support options**
- **Fees and refunds**
- **Privacy and data handling**
- **Certification & record keeping**

3) Training & Assessment Requirements

Your trainer will explain:

- how today's training and assessment will work
- timeframes for assessment
- assessment methods
- that training and assessment is completed in English

4) Certification Outcome

If you complete all assessment tasks satisfactorily, you will be deemed Competent and you will receive:

- A Statement of Attainment: CPCCLSF3001: Licence to Erect, Alter and Dismantle Scaffolding Intermediate Level

Before leaving today, check your full name and date of birth are correct.

5) The venue

Your trainer will explain:

- Toilets and facilities
- Emergency exits and procedures
- Where to refill water bottles
- Rules regarding smoking and vaping i.e. smoking/Vaping are not allowed inside the venue. If you need to smoke or vape, you must go outside the venue.

6) Mobile Phones

During the assessment, mobile phones are strictly forbidden. All assessment answers must be completed in English without the use of a mobile phone.



7) Attendance

100 percent attendance is required for this course

8) Questions & Support

If you have questions or need support, speak with your trainer at any time. Your Learner Guide was sent via email as a downloadable link and will also be emailed again after the course with your certificate.

Your enrolment should be complete. If not, you must complete your enrolment now. If you did not provide us with a USI on enrolment it is essential you have this to us today. Please do this in your own time today and supply it to the trainer by the end of the day to not hold up and delay the class. It is not possible to get your certification without having a USI. If you have issues with the USI not matching your name, please call **1300 857 536**.

Get a USI	Find My USI
 <p>SCAN ME</p>	 <p>SCAN ME</p>

1.1 Introduction

These training materials are based on the National High Risk Licence Unit of Competence **CPCCLSF3001: Licence to Erect, Alter and Dismantle Scaffolding Intermediate Level.**

Scaffolding work is undertaken in construction and other industries where temporary structures are erected, altered and dismantled.

This unit applies to scaffolding work involving:

- Cantilevered crane loading platforms.
- Cantilevered scaffolds.
- Spur scaffolds.
- Barrow ramps and sloping platforms.
- Scaffolding associated with perimeter safety screens and shutters.
- Mast climbing work platforms.
- Tube and coupler scaffolds (including tube and coupler covered ways and gantries).



You will learn about:

- Planning out your work.
- Selecting and inspecting equipment.
- Setting up for the task.
- Erecting and dismantling scaffolding.

1.1.1 When is a High Risk Licence Needed?

National Courses PTY LTD

A high risk work licence allows you to lawfully work with certain high risk equipment and plant such as forklifts, cranes, hoists, elevating work platforms, scaffolding, rigging and pressure equipment. There are 3 levels of scaffolding class under a high risk licence.

This course covers the work associated with the intermediate scaffolding (SI) class of high risk work licence involving erecting, altering or dismantling a temporary structure to support a platform from which a person or object could fall more than four metres.



Competence in this unit does not in itself result in a licence. A licence is obtained after competence is assessed under applicable Commonwealth, state or territory work health and safety (WHS) regulations.

1.1.2 What Types of Work can you do with a Scaffolding Intermediate Level Licence?

A person with an intermediate scaffolding licence is legally allowed to carry out the following tasks:

- All basic scaffolding tasks.
- Erection, alteration and dismantling of modular and prefabricated scaffolds.
- Erection of cantilevered materials hoists with a maximum working load limit of 500 kilograms.
- Use of ropes and gin wheels.
- Installation of safety nets.
- Use of static lines.
- Erection of bracket scaffolds (tank and formwork).
- Installation of cantilevered crane loading platforms.
- Erection and dismantling of cantilevered and spurred scaffolds.
- Erection and dismantling of barrow ramps and sloping platforms.
- Scaffolding associated with perimeter safety screens and shutters.
- Erection and dismantling of mast climbers.



- Erection, alteration and dismantling of tube and coupler scaffolds including tube and coupler covered ways and gantries.

1.1.3 High Risk Work Licence Requirements

Once you pass your assessment you will have 60 days to apply for your licence.



You must renew your licence within 12 months of its expiry otherwise:

- Your licence can't be renewed.
- You need to repeat the course and re-apply for your licence.
- You need to enrol in the course again and be supervised by somebody who has a current licence for the same class.

You can still do high risk work without a licence as long as:

- You are enrolled in a high risk course for the class, and
- You are being supervised by somebody who has a licence for the same class.

National Courses PTY LTD

As part of their legal duty of care, licensed workers must take reasonable steps to make sure the way they work does not impact on the safety of themselves or any others on site. Failing to work safely can result in the health and safety regulator:

- Suspending or cancelling your licence.
- Refusing to renew your licence.
- Ordering that you are reassessed to ensure you are competent.
- Taking action to prosecute.



Your employer should ask you for evidence that you have a high risk licence before you start any high risk work. You can show them:

- Your licence.
- Proof from the training company that you have passed your assessment.
- Proof that you are currently completing a course for high risk work.

1.2 Types of Scaffolding

You will need to decide what type of scaffold construction is the most appropriate for the tasks you need to perform.



The purpose for which the scaffold will be used should be a factor in making the decision of which type of scaffold should be selected.



You should also consider the specified building's design, shape, and location as well as the scaffold's ability to adapt to the structure's contours.



1.2.1 Basic Level Scaffolds



The following table outlines the main types of basic level scaffolds.

Name	Description	Example
<p>Mobile Scaffold</p>	<p>A Mobile Scaffold is an independent, free-standing, movable scaffold mounted on castors. It is useful for maintenance where multiple points must be accessed.</p> <p>Castors for mobile scaffolds need to have wheel locks or chocks. Castors for a mobile scaffold cannot have a pneumatic tyre. Plan bracing is needed in a mobile scaffold to stop the scaffold from twisting when it is moved.</p>	
<p>Birdcage Scaffold</p>	<p>A Birdcage Scaffold consists of more than two rows of standards, connected by ledgers and transoms. It is intended for use on one level only, and is commonly used for working on a ceiling.</p>	

<p>Modular or Frame Scaffolding</p>	<p>A Modular or Frame Scaffolding (steel, fibreglass or aluminium) is assembled from prefabricated frames, braces and accessories.</p> <p>Free-standing modular scaffolds can be built to a height of 3 times the minimum base width.</p>	
<p>Bracket Scaffold</p>	<p>A Bracket Scaffold is a scaffold that has a platform carried on frames attached to or supported by a permanent or temporary construction.</p> <p>Bracket scaffolds are often used for maintenance work.</p>	
<p>Tower Scaffold</p>	<p>A Tower Scaffold can be a mobile, modular, or tube and coupler variety. Tower scaffolds are generally fitted with a single work platform with ladder access and have only 2 rows of standards. Tower scaffolds are popular where there is a limited amount of space to erect a scaffold.</p> <p>Unless otherwise stated by the manufacturer, a light duty aluminium tower scaffold should not exceed a height of 9 metres.</p>	

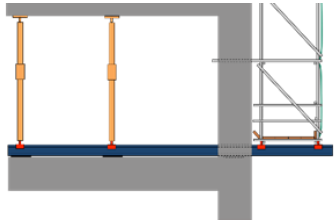
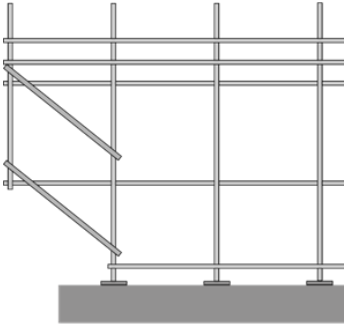

1.2.2 Intermediate Level Scaffolds

The following table outlines the main types of intermediate level scaffolds.

Name	Description	Example
<p>Tube and Coupler Scaffold</p>	<p>A Tube and Coupler Scaffold is erected using scaffold tubes connected with couplers.</p> <p>These are useful where the scaffold must be erected in a specific shape to match a structure, or prefabricated scaffolds will not meet the requirements of the task.</p>	
<p>Single Pole Scaffold</p>	<p>A Single Pole Scaffold contains a single row of standards, and is completely dependent on the structure it is placed against for support.</p> <p>A single pole scaffold is often used for bricklaying or other masonry work.</p>	
<p>Cantilever Scaffold</p>	<p>A Cantilever Scaffold is a scaffold that is supported by cantilevered load-bearing members.</p> <p>It is commonly used where surface conditions are unacceptable, or the required height of the work platform makes conventional scaffolds unsuitable.</p>	
<p>Spurred Scaffold</p>	<p>A Spurred Scaffold is partially supported by inclined load-bearing members called 'spurs'.</p> <p>They are used where there is insufficient load bearing capability for standards, or where the scaffold must be configured in a way that does not have all standards resting on the ground/supporting structure. An example of this is a scaffold that is built around and above an entryway.</p>	

1.2.3 Advanced Level Scaffolds

The following table outlines the main types of advanced level scaffolds.

Name	Description	Example
<p>Suspended or Swing Stage Scaffold</p>	<p>A Suspended or Swing Stage Scaffold can be either raised or lowered, as it has a suspended platform.</p> <p>These types of scaffolds are commonly associated with window washers.</p>	
<p>Hung Scaffold</p>	<p>Hung Scaffolds are temporary structures suspended by tubes, wire ropes or chains from a permanent structure and are used to access areas that would otherwise be difficult or unsafe to access by other means.</p> <p>They are usually made from steel, aluminium or timber components.</p> <p>Hung scaffolds CANNOT be raised or lowered when in use. Some can, however, travel horizontally with the aid of girder trolleys or mobile suspension rigs.</p>	

1.2.4 Scaffold Duty

Scaffolds have different size requirements and rated capacities according to their duty:

Duty	Minimum Working Platform Width	Maximum Load Allowed on Platform
<p>Light Duty</p>	<p>450mm</p> <p>This is the minimum clear access required for a non-working or access only platform.</p>	<p>225kg per bay</p>
<p>Medium Duty</p>	<p>675mm</p>	<p>450kg per bay</p>
<p>Heavy Duty</p>	<p>900mm</p>	<p>675kg per bay</p>

The configuration and the parts that make it up generally determine the duty of a scaffold.

You need to make sure the scaffold you intend to erect will be the correct duty depending on the requirements of the job, and the types of loads that will be resting on the scaffold while it is erected.

You should check the manufacturer or supplier specifications for the exact rated capacity of the working platforms of a scaffold. Do this during the planning stage, this will make sure the scaffold can support the weight of any workers, tools, equipment and materials required for the job.

1.3 Plan the Job

Careful planning is the first step in completing a task safely. Make sure you are aware of all of the requirements of the job, and the steps required to carry it out properly so you can help to keep the work site and workers as safe as possible.

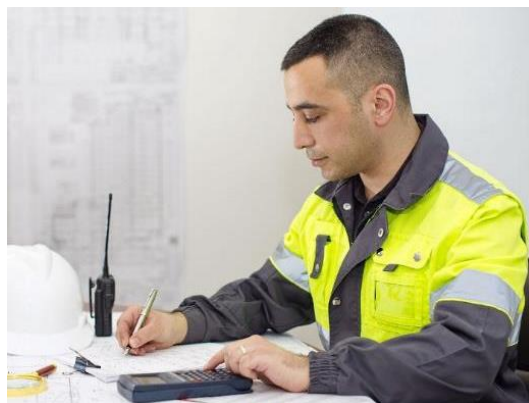

1.3.1 Assess the Task and Gather Site Information



The first thing to do when planning a task is to work out exactly what it is you need to do. Simply put, you will need to assess the task.

To do this, you will need to collect all the information you require about the tasks, personnel, local site conditions and equipment.

Site information may include details about:

- The location and specifics of the task.
- Ground conditions and suitability.
- Hazards that exist on site or that are associated with the completion of the task.
- Access and egress (entry and exit) to the work area.
- Equipment that is being used on site.
- Plant and equipment required for the task.
- Availability of equipment.
- Induction and training.
- Weights and any other relevant information that can help you plan the job.



National Courses PTY LTD

You can find work instructions and site information in documentation such as:

- Work Method Statements (WMS).
- Site-specific Job Safety Analyses (JSA).
- Task plans.
- Manufacturer's specifications.
- Legislation and regulations.
- Relevant Australian Standards.
- Management Plans.
- WHS/OHS Policy.
- Code of practice.
- Operations manuals.
- Safe working or job procedures.
- Risk assessment.

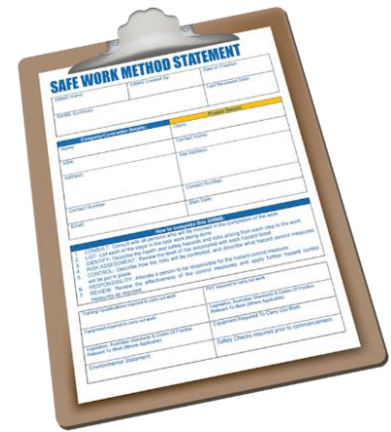

Make sure you can accurately interpret and understand structural charts and plans. They will help you decide which scaffolding equipment and tools you will need and what methods and procedures you will use throughout the task. They will also help you to identify evacuation routes, no-go zones or high-risk areas on site.

1.3.1.1 Identify Forces and Loads

A 'load' is any type of force exerted on an object. It is important to understand the relevant forces and loads that are associated with the scaffolding work you will be doing.

Forces and loads apply to scaffolds and the structures they are attached to.



When constructing a scaffold there are a range of forces and loads you may need to consider:

- **Dead Loads** – The weight of a scaffold or hoist and its components before it is loaded.
- **Live Loads** – The weight of the equipment and personnel on the scaffold (in each bay).
- **Static Load** – A load that is not moving (consistent load).
- **Dynamic Load** – Force made by a moving load on a resisting structure or component.
- **Wind Load** – The force made by wind on a structure or its components.
- **Environmental Load** – The weight of environmental factors such as water, ice, rain, dust and debris that may be on the scaffold.



Each standard is designed to hold at least 1/4 of the duty live load per platform, per bay.

For example, a medium duty scaffold that can hold 450kg per bay requires each standard to hold at least 112.5kg.

It is important to know the weight of any material you place on a scaffold. If you place too much weight on a scaffold it may collapse.

Some loads may have the weight marked on them or they may come with a consignment note or weighbridge certificate.

You may have to calculate the weight of a load using appropriate mathematical procedures and formulas. Remember to add the weight of pallets, boxes and drums when lifting loads.

The weights of some common materials can be found in the table below.

Materials	Weight
Cubic Metre of Concrete	2.4 metric tonnes
Cubic Metre of Water	1 metric tonne
Cubic Metre of Earth or clay	1.9 metric tonnes
Cubic Metre of Steel	7.84 metric tonnes

1000 Common Bricks	4 metric tonnes
---------------------------	-----------------

1.3.2 Work Health and Safety Requirements

Work Health & Safety (WHS) is defined as laws and guidelines to help keep your workplace safe.

These can be broken down into four main types:

Law	Explanation
Acts	Laws to protect the health, safety and welfare of people at work.
Regulations	Gives more details or information on particular parts of the Act.
Codes of Practice	Are practical instructions on how to meet the terms of the Law.
Australian Standards	Give you the minimum levels of performance or quality for a hazard, work process or product such as AS/NZS 1576. Note: other valid Australian Standards may also apply.

1.3.3 Duty of Care

All personnel have a legal responsibility under duty of care to do everything reasonably practicable to protect themselves and others from harm by complying with safe work processes.

This includes activities that require licences, tickets or certificates of competency or any other relevant state and territory WHS requirements.



The following personnel have a duty of care:

- Employers and self-employed persons.
- Persons in control of the workplace.
- Supervisors.
- Designers.
- Manufacturers.
- Suppliers.
- Workers.
- Inspectors.



To meet their duty of care obligations an employer is required to provide and maintain a work environment without risks to health and safety. This includes providing and maintaining safe plant and structures as well as safe systems of work. Adequate facilities need to be provided by the employer to meet the needs of everyone on site.

They must also ensure that everyone has received adequate training, information, or supervision to complete their work. This includes providing sufficient information, training, instruction and/or supervision to individuals who have recently completed their High Risk Work Licence and are going to be completing unfamiliar scaffolding

work.

Intentionally or recklessly interfering with or misusing any WHS equipment provided by your employer is a breach in duty of care. You must cooperate with the health and safety policies and procedures set out by your employer, doing this will assist you in meeting your duty of care obligations.

1.3.4 Work Method Statements

A Work Method Statement (WMS) details how specific hazards and risks, related to the task being completed, will be managed and is developed by the employer for their workers.

WMS fulfil a number of objectives:

- They outline a safe method of work for a specific job by identifying associated hazards and giving instructions of how these need to be managed.
- They provide an induction document that workers must read and understand before starting the job.
- They assist in effectively coordinating the work, the materials required, the time required, and the people involved to achieve a safe and efficient outcome.
- They are a quality assurance tool.



To complete a WMS:

1. Break the job down into logical steps taking into consideration what is required to be achieved by the task.
2. Against each step, identify the workplace hazards in this activity i.e. the ways that a person (or plant) could be injured or harmed (or damaged) during each step.
3. Decide on measures required to mitigate hazards i.e. what could be done to make the job safer and prevent injuries or harm that may occur.
4. Identify roles and responsibilities for actions and outcomes to make sure risk/hazard controls are carried out under supervision.
5. Ensure the WMS is fully understood by all personnel prior to commencing the task.



Work Method Statements must be available for inspection at any given time.

Work Method Statements may also be referred to as Safe Work Method Statements (SWMS), Safe Work Procedures (SWP) or Job Safety Analysis (JSA). It must be prepared in consultation with those people who will be doing the job.

1.3.5 Manufacturer Documentation

All the equipment and tools used for scaffold work, erection and dismantling will have manufacturer documentation, also called manufacturer instructions.

This documentation may include:

- Instructions for assembly and use.
- Maintenance schedules.
- End of use guidelines.
- Known hazards or risks.
- Important contact details for repairs or enquiries.



It is important that you follow the guidance provided in manufacturer documentation as this will ensure all tools and equipment are being used safely. Reviewing this documentation is an important part of meeting WHS responsibilities.



Not following guidance given in the manufacturer's instructions can lead to unsafe work practices which could lead to illness, injury or in some cases death.

Manufacturer's instructions are often referred to when conducting a risk assessment, or training personnel on how to use a new tool or install a piece of equipment.

If you are not sure where to locate these documents, then ask your supervisor or manager.

1.4 Identify and Control Hazards



You may need to identify and manage risks on the work site which expose yourself, or others to injury, illness or disease. This will involve inspecting the work environment as well as the tasks being done.

A **HAZARD** is the thing or situation with the potential to cause injury, harm or damage to a person, equipment or the environment.

A **RISK** is the possibility of harm (death, injury or illness) occurring if someone was exposed to a hazard.

If you can remove or at least control a **HAZARD** you can reduce the **RISK** involved.

The aim of **risk management** is to reduce the amount of risk in the workplace, this is done by removing or managing hazards that people are exposed to at work.

1.4.1 Hazard Identification

Part of your job is to look around to see if you can find any hazards before you start.

A good tip is to check:

- **Above head height** – remember that scaffolding may be above your head.
- **At eye level** – look around to see if there is anything in the way of where you want to place the scaffold.
- **On the ground (and below)** – Have a look at the ground conditions - will it support the weight of the scaffold and load?



Common workplace hazards include:

National Courses PTY LTD

- Ground conditions:
 - Underground services.
 - Non-weight bearing surfaces.
 - Recent excavations.
 - Soil conditions (e.g., recently filled trenches).
- Poor lighting.
- Overhead hazards:
 - Power lines.
 - Overhead service lines.
 - Obstructions.
 - Falling objects.
- Surrounding structures:
 - Buildings.
 - Obstructions.
 - Facilities.
 - Trees.
 - Equipment.
- Traffic:
 - Pedestrians.
 - Personnel.
 - Vehicles.
 - Mobile plant.
- Weather:
 - Wind.
 - Lightning.
 - Rain.
- Workplace-specific hazards:
 - Dangerous materials.
 - Falling from heights.



1.4.1.1 Consultation and Communicating with Others

Make sure you talk to the following people about hazards before you start work:



- Safety officers.
- Site engineers (where applicable).
- Supervisors.
- Colleagues.
- Managers who are authorised to take responsibility for the workplace or operations.
- Health and safety representatives.

These personnel may be aware of hazards you have not noticed or have expertise on how to manage hazards on site.

Open communication with others helps to make sure everyone is aware of any workplace policies, site-specific procedures and hazards.

1.4.2 Working Near Power Lines

Working near power lines can be dangerous if you are not careful.

It is very important that you know the safe operating distances for different types of power lines and the steps you must take if your job needs you to work closer than the safe distances.

Generally, if you need to work closer than the safe work distance you must:

- Contact the local electrical authority for permission to work closer (this is called an exemption).
- Have the power lines shut off. If this is not possible then have the power lines insulated.
- Use a spotter (depending on local laws and rules).



Distances are different depending on the state or territory you are working in and the voltage of the power lines. You should check with the local electrical authority for information and advice to find out the voltage of power lines in your work area.

Queensland

The Queensland Electrical Safety Regulation breaks down the distances in detail. Exclusion zones are broken down not only by size of power line but also by the competency level of the operator. This means that the requirements should be clarified with the electrical authority before work commences even if the distance appears to be outside the zones.

The following minimum distances are provided as guidance for any untrained person working on the erection or disassembly of scaffolds. The code of practice defines these distances under the category of a person, including any object that person is handling, not as operating plant.

Power Line Type	Distance
Up to 132kV	3.0m
Above 132kV up to 220kV	4.5m
Above 220kV up to 275kV	5.0m
Above 275kV	6.0m

New South Wales

When erecting, dismantling and using metallic scaffolding in NSW, the 4m or greater approach should be used. This is explained in the NSW Code of Practice: Work Near Overhead Powerlines. If there is a risk that 4m distance cannot be maintained between workers and overhead power lines, then the network operator should be contacted to assist in determining the safest way to complete the work.

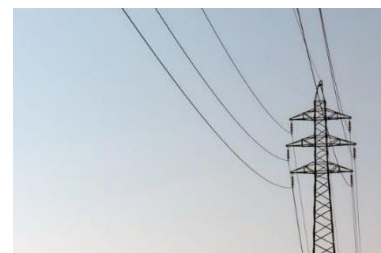

Australian Capital Territory

In the ACT mobile plant operators and persons erecting or working from scaffolding must maintain a safe minimum distance to power lines as outlined in the table below:

Power Line Type	Distance
Less than 33kv	4.0m
33kV or more (transmission lines)	5.0m

Victoria

In Victoria the Framework for Undertaking Work Near Overhead and Underground Assets states that equipment must not be closer than the following distances to power lines:

Power Line Type	Distance
Distribution lines up to and including 66kV (power poles)	6.4m (or 3.0m with a qualified spotter)
Transmission lines greater than 66kV (towers)	10m (or 8m with a qualified spotter)

Tasmania

In Tasmania equipment must not be closer than the following distances to power lines:

Power Line Type	Distance
Up to and including 133kV (poles)	6.4m (or 3m with a safety observer)
Greater than 133kV (towers)	10m (or 8m with a safety observer)

South Australia

In South Australia mobile plant operators and persons erecting or working from scaffolding must maintain a safe minimum distance to power lines as outlined in the table below:

Power Line Type	Distance
Up to 132kv (including 132kv poles)	6.4m (or 3.0m with a spotter)
132kv or more (including 132kv towers)	10.0m (or 8.0m with a spotter)

Western Australia

In Western Australia this falls under Regulation 3.64 from the OSH Regulations and states the following as the minimum distances:

Power Line Type	Distance
Up to 1kV (insulated)	0.5m
Up to 1kV (uninsulated)	1.0m
Above 1kV and up to 33kV	3.0m
Above 33kV	6.0m

Northern Territory

In the Northern Territory equipment must not be closer than the following distances to power lines:

Power Line Type	Distance
Up to and including 132kV (distribution lines)	6.4m (or 3m with a spotter)
Greater than 132kV (transmission lines)	10m (or 8m with a spotter)

1.4.2.1 Power Line Visual Indicators



There are a range of different indicators in use across the country to identify the position of overhead power lines.

Important: Visual indicators **DO NOT** insulate the power lines so exclusion zones and safe operating distances must still be used, even when any of these systems are in use.

Tiger Tails and Coloured Markers

Tiger tails or coloured markers are used to clearly show the location of overhead power lines. Poles may also be coloured up to 3m from the ground.

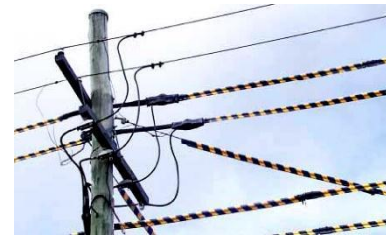

Marker Balls or Flags

Marker balls are fixed to the power line and are often red or another bright colour.



Safety, Warning and Danger Signs

Signage may also be present to warn of overhead power lines and services.



1.4.3 Risk Assessment

Once you have identified the hazards on site or related to the work you will be doing you need to assess their risk level.

Risk levels are worked out by looking at 2 factors:

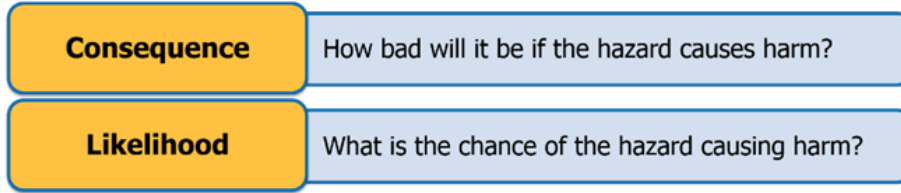

You can use a table like the one shown here to work out the risk level:

	Consequence				
	1. Insignificant	2. Minor First Aid Required	3. Moderate Medical Attention and Time Off Work	4. Major Long Term Illness or Serious Injury	5. Catastrophic Kill or Cause Permanent Disability or Illness
Likelihood					
1. Rare	Low	Low	Moderate	Moderate	Moderate
2. Unlikely	Low	Low	Moderate	Moderate	High
3. Possible	Low	Moderate	High	High	Extreme
4. Likely	Moderate	Moderate	High	High	Extreme
5. Almost Certain	Moderate	High	High	Extreme	Extreme

For example, a hazard that has a **Major** consequence and is **Almost Certain** to occur has a risk level of **Extreme**.

	Consequence				
Likelihood	1. Insignificant	2. Minor First Aid Required	3. Moderate Medical Attention and Time Off Work	4. Major Long Term Illness or Serious Injury	5. Catastrophic Kill or Cause Permanent Disability or Illness
1. Rare	Low	Low	Moderate	Moderate	Moderate
2. Unlikely	Low	Low	Moderate	Moderate	High
3. Possible	Low	Moderate	High	High	Extreme
4. Likely	Moderate	Moderate	High	High	Extreme
5. Almost Certain	Moderate	High	High	Extreme	Extreme

The risk level will help you to work out what kind of action needs to be taken, and how soon you need to act.

The table below is an example of a site risk policy:

Risk Level	Action
Extreme	This is an unacceptable risk level. The task, process or activity must not proceed .
High	This is an unacceptable risk level. The proposed activity can only proceed, provided that: <ol style="list-style-type: none"> 1. The risk level has been reduced to as low as reasonably practicable using the hierarchy of risk controls. 2. The risk controls must include those identified in legislation, Australian Standards, Codes of Practice etc. 3. The risk assessment has been reviewed and approved by the Supervisor. 4. A Safe Working Procedure or Work Method Statement has been prepared. The supervisor must review and document the effectiveness of the implemented risk controls.
Moderate	This is an unacceptable risk level. The proposed activity can only proceed, provided that: <ol style="list-style-type: none"> 1. The risk level has been reduced to as low as reasonably practicable

	<p>using the hierarchy of risk controls.</p> <ol style="list-style-type: none"> 2. The risk assessment has been reviewed and approved by the Supervisor. 3. A Safe Working Procedure or Work Method Statement has been prepared.
Low	The proposed task or process needs to be managed by documented routine procedures, which must include application of the hierarchy of controls.

The action you take will depend on:

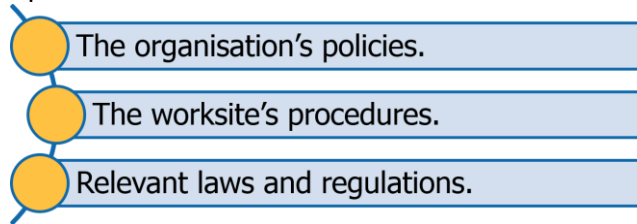

1.4.4 Hazard Controls

Once hazards and risks have been identified and assessed you need to work out what the best way to manage them will be.

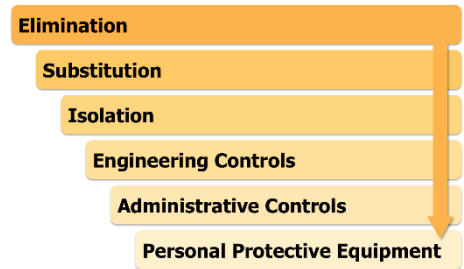

The Hierarchy of Hazard Control is the name given to a range of control strategies used to eliminate or control hazards and risks in the workplace. Hazard controls should be applied before you start work, or as soon as a hazard is identified during work operations.

The Hierarchy has 6 levels.

Always start at the top of the list and work your way down.

Hierarchy Level	Explanation
1. Elimination	Completely remove the hazard. This is the best kind of hazard control.
2. Substitution	Swap a dangerous work method or situation for one that is less dangerous.
3. Isolation	Isolate or restrict access to the hazard.
4. Engineering Controls	Use equipment to lower the risk level.
5. Administrative Controls	Site rules and policies attempt to control a hazard. Includes Safe Work Practices.
6. Personal Protective Equipment	The least effective control. Use PPE while you work. This should be selected at the planning stage of your work, and checked before starting the job.

You may need to use a range of control measures to reduce the risk to an acceptable level.

1.4.4.1 Controlling Traffic Hazards

If the work area is going to be shared with pedestrians, site personnel, vehicles or mobile plant, you will need to make sure you have selected appropriate control measures.

This may involve isolating the work area by setting up barricades and signage to warn others that you are working in the area and that it is dangerous for them to come too close.



This may include:

- Using a flag person to control traffic.
- Setting up flashing hazard lights.
- Organising hoardings, gantries or scaffolding.
- Setting up warning signs and barriers.
- Setting up pedestrian and vehicle exclusion zones.

Worksites that require the management of traffic will have a traffic or vehicle management plan. These plans will show you where to place hazard controls including signage, barricades and flag persons.

1.4.4.2 Controlling Equipment Hazards

If the scaffold is to be constructed within the working radius of a crane on site, or close to other equipment with moving parts there is a hazard of the scaffolding being struck or hit by the crane or equipment.

In this situation you will need to implement a number of control strategies including:

- Safety exclusion zones to prevent access to the dangerous area – this may include a flag person.
- Workplace communications to assist in coordinating movements within the work area.
- Barriers or other physical means of preventing the equipment from making contact with the scaffold or injuring personnel on site.



2.1 Prepare for Scaffolding Work



You will need to plan all the details of how you intend to carry out the task, how you intend to deal with any unidentified hazards and what components you will use to complete the scaffold.

You should document these details in a scaffolding plan.

The procedures and techniques you plan to use to complete your tasks should conform with all legal requirements related to scaffolding work.

Scaffolding plans are used to make sure everyone clearly understands what they need to do to meet safety requirements and avoid misunderstandings on site.

2.1.1 Scaffolding Plan

The details of the scaffold plan may include:

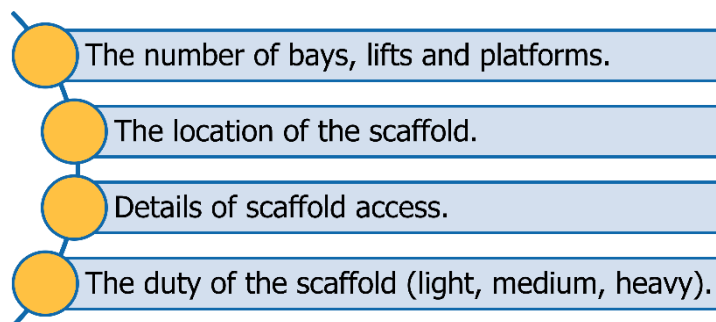

When you are putting the scaffolding plan together you should consult with other people involved in the job. They may have expertise or experience that is valuable to the planning of the task.

Personnel you may consult with include:

- Supervisors.
- Designers or engineers.
- Doggers or riggers.
- Managers responsible for workplace/operations.
- Other scaffolders/site workers.





Your plan will need to refer to other relevant plans, drawings and documentation such as work method statements or site procedures.

These documents can be used as a reference to determine the scaffold elements/parts that are required to erect it and the configuration of work platforms, ladder access and other components or associated equipment.

Make sure everybody involved in the scaffolding work is familiar with the plan and understands what they need to do.

2.1.2 Scaffold Task Requirements

It is important that you are familiar with the configurations and limitations of scaffolds, especially when considering different duty scaffolds, different materials (aluminium or steel) and methods of access. All of these factors will influence the design of the scaffold.



The following tables will help you to identify the limitations of different scaffolds and the allowable number of full-length working platforms (assuming that all but the base lift may potentially be used as a working platform).

Light Duty Scaffold

Maximum number of full-length working platforms on light duty scaffold: Access from base lift				
Tube Type	Scaffold Height			
	8m	8m – 16m	16m – 24m	24m – 33m
Aluminium	4	N/A	N/A	N/A
Steel	4	3	N/A	N/A

Maximum number of full-length working platforms on light duty scaffold: Access from building				
Tube Type	Scaffold Height			
	8m	8m – 16m	16m – 24m	24m – 33m
Aluminium	4	4	3	3
Steel	4	7	6	6

Medium Duty Scaffold

Maximum number of full-length working platforms on medium duty scaffold: Access from base lift				
Tube Type	Scaffold Height			
	8m	8m – 16m	16m – 24m	24m – 33m
Aluminium	1	N/A	N/A	N/A
Steel	4	1	N/A	N/A

Maximum number of full-length working platforms on medium duty scaffold: Access from building				
Tube Type	Scaffold Height			
	8m	8m – 16m	16m – 24m	24m – 33m
Aluminium	3	2	2	2
Steel	4	5	5	4

Heavy Duty Scaffold

Maximum number of full-length working platforms on heavy duty scaffold: Access from base lift				
Tube Type	Scaffold Height			
	8m	8m – 16m	16m – 24m	24m – 33m
Aluminium	N/A	N/A	N/A	N/A
Steel	4	N/A	N/A	N/A

Maximum number of full-length working platforms on heavy duty scaffold: Access from building				
Tube Type	Scaffold Height			
	8m	8m – 16m	16m – 24m	24m – 33m
Aluminium	2	2	2	2
Steel	4	4	3	3

Note: Light duty platforms are 0.45m x 1.5m per bay. Medium duty platforms are 0.9m x 1.8m per bay. Heavy duty platforms are 1.0m x 2.4m per bay. In the tables above 'N/A' represents a scaffold configuration that is not allowed.

Information obtained from the site or client will help you design an appropriate scaffold for the situation. The following is an example of the information that you may be provided with when planning out the task and preparing the scaffolding plan.

Scaffold Design Requirements:

- Independent tube and coupler scaffold (max lift height of 2m).
- Scaffold is heavy duty (steel tube).
- Height of top lift is 8m.
- Length between end standards is 14.4m.
- Centre-to-centre transverse standard spacing 1.05m.
- Number of working platforms is 3 full-length working platforms.
- Location of platforms is on the upper 3 lifts.
- Safety screens must be used.
- Ladder access is required.
- Standards must be staggered.
- Platform planks are 225mm (wide) x 32mm (thick), Hardwood.
- Platform width is 4 planks between the standards.



Available tube lengths (metres):

- 1.2 ● 2.1 ● 3.0 ● 4.2 ● 5.4 ● 6.0
- 1.5 ● 2.4 ● 3.6 ● 4.8 ● 6.3
- 1.8 ● 2.7

Available plank lengths (metres):

- 2.7 ● 3.6

Scaffold Erection Requirements:

- Edge protection is guardrails, midrails and toeboards on outside and ends of platforms.
- Longitudinal bracing will be fixed to each outside panel in the end bays and in one intermediate bay.
- Ledgers will be fixed to the inside of the standards.
- The first lift will be fixed with transoms set below the ledgers.
- The working lifts will be fixed with putlogs and putlog couplers.
- Putlogs are required on non-working platforms to carry planks for erection purposes.
- Guardrails are required on non-working platforms.
- Working lifts fixed with putlog couplers require transoms set below ledgers.
- Non-working lifts require transoms or putlogs fixed with right-angle couplers.
- Braces will be fixed to the standards with swivel couplers.
- Guard rails and mid rails will be fixed to the standards with right angle couplers.
- All joints will be fixed with sleeve-type end-to-end couplers.
- Handballing is only feasible up to the second lift. A gin wheel or materials hoist may be required for the erection of the higher lifts.

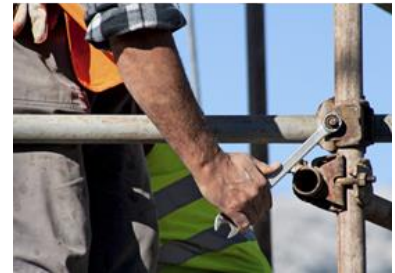

Relevant Site Information:



- Scaffold may be tied to the building.
- Ground surface is suitable for erection of the scaffold.
- There are no cranes or other mobile plant working or traveling in the vicinity of the proposed scaffold site.
- Access and egress to the work area is suitable.
- There is no electricity within 8m of the scaffold.
- Pedestrians will be restricted from access to the scaffold by means of barriers, fences and signage.

2.1.3 Scaffold Drawings

The drawing/design will help you to work out what parts you will need. Shown here is a drawing of the scaffold that would be used to meet these design and erection requirements:

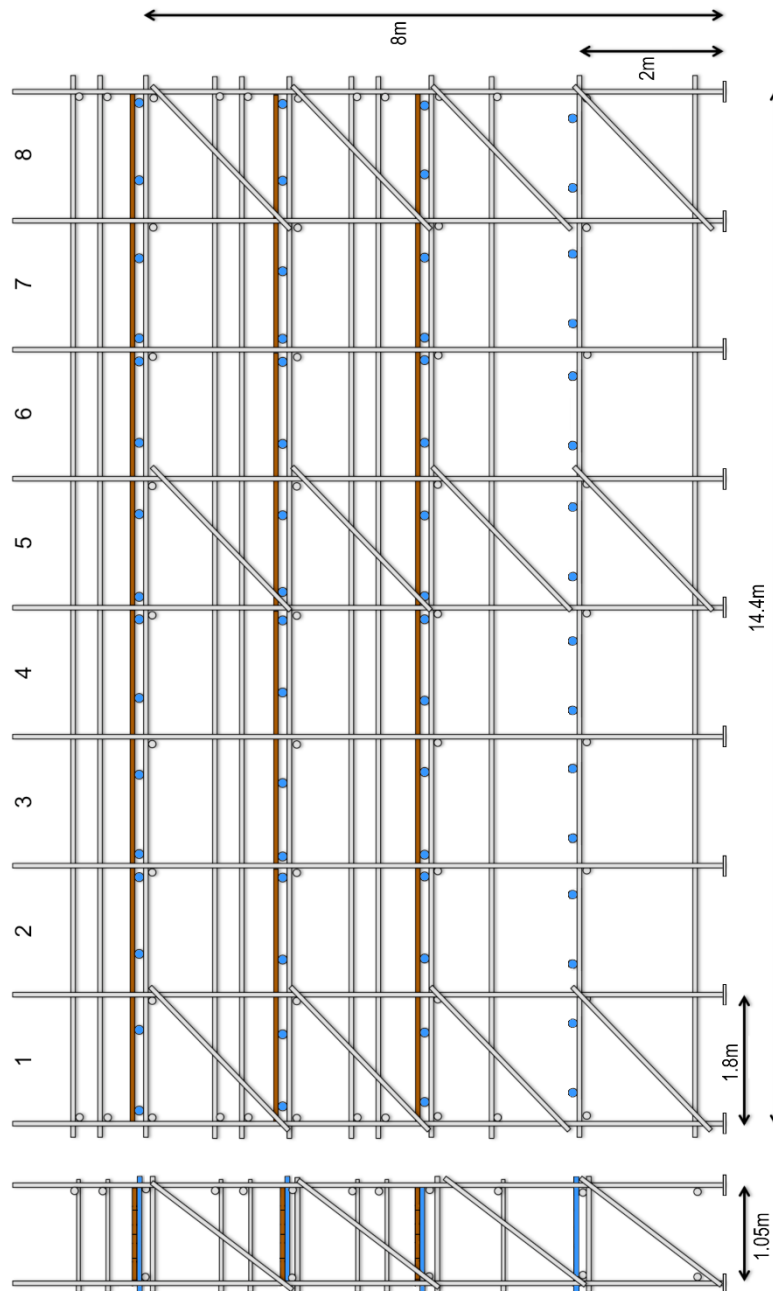

Note: Putlogs marked in blue. Ladders, toeboards and screens have been omitted for clarity.

Standards and ledgers need to be properly spaced and joined to maintain the stability of the scaffold. Incorrect positioning of tube ledger joints can lead to the failure of the scaffold while under load. Shown here is an example of how the tubes could be joined (using the tube lengths provided):



Standard Spacing:

The standard lengths shown give a joint spacing of within 300mm of a ledger while also allowing all standards to be fixed to a ledger.

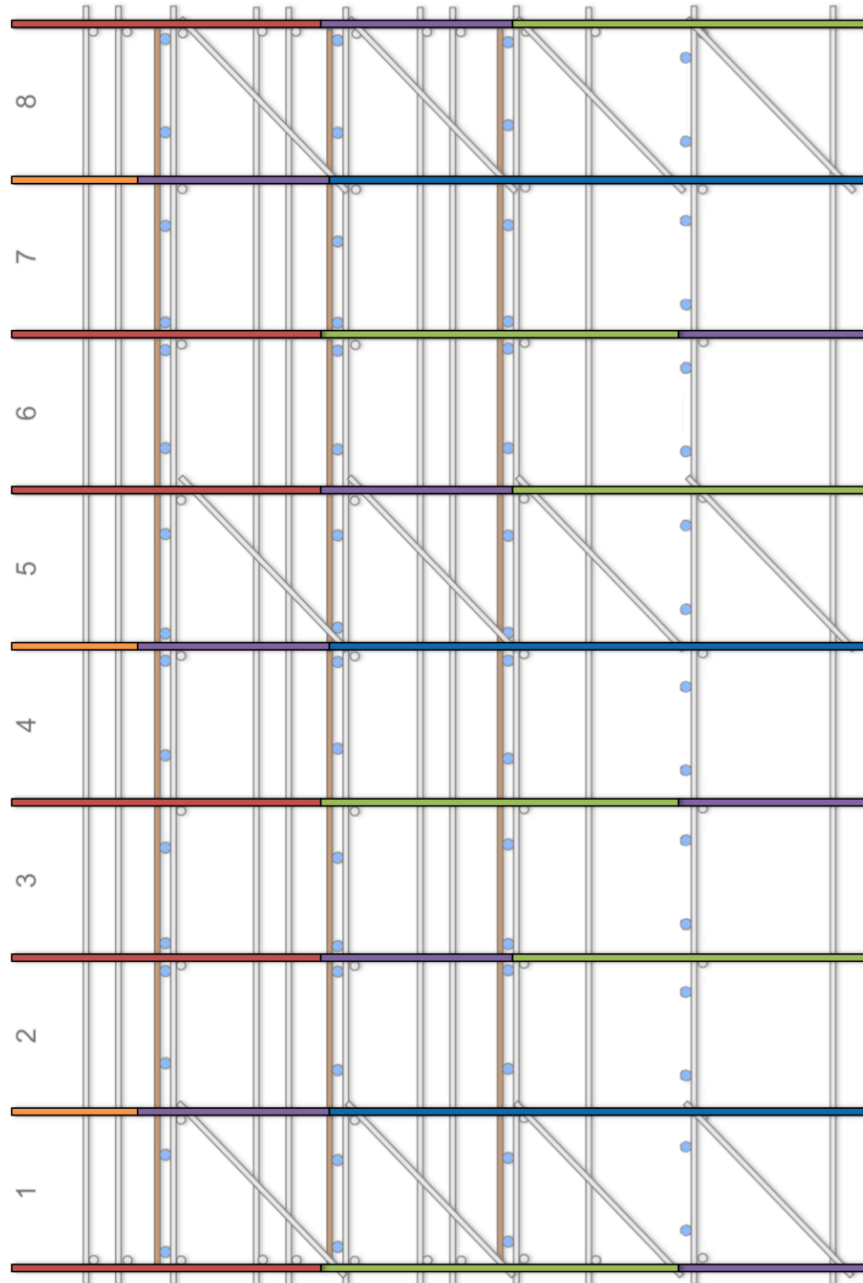

Ledger Spacing:

The ledger lengths shown avoid end bay joints (which are not allowed) while enabling joints to occur within 300mm of a standard.

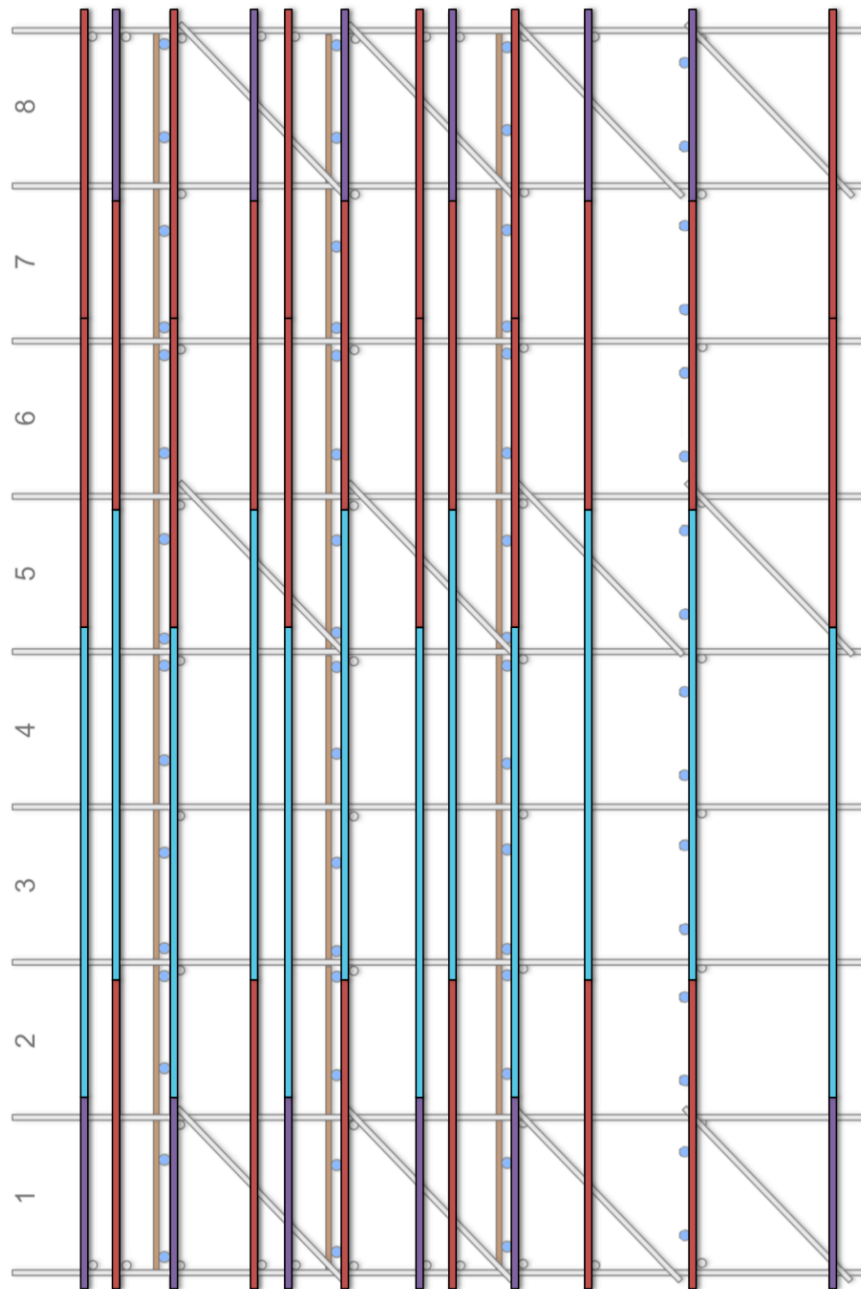

Note: Transom joins have not been provided in the drawing as they cannot be joined for a scaffold.

It is important that your drawings make note of the tie in points on the scaffold:

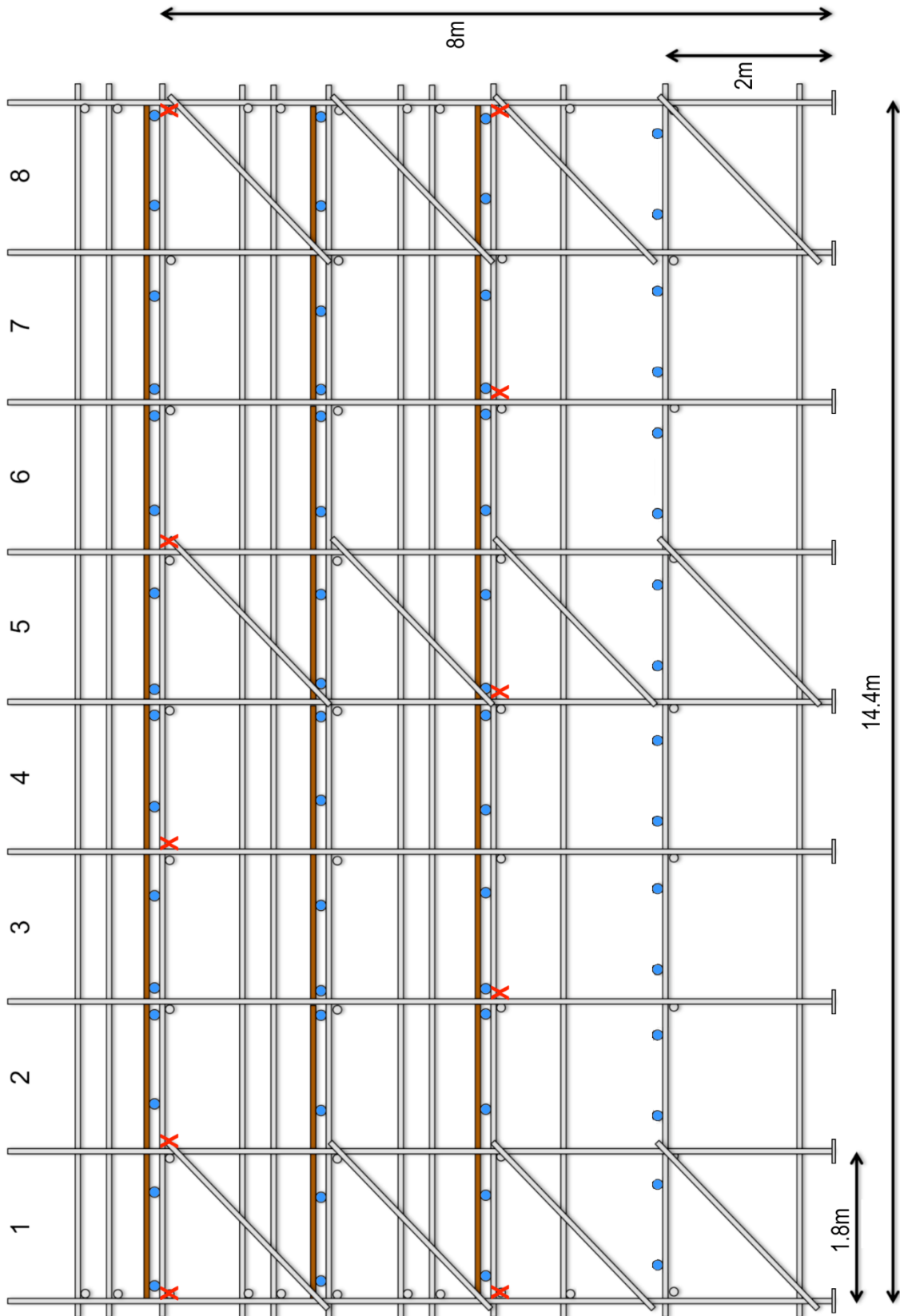

You may also need to mark where swivel clips/couplers are being used:

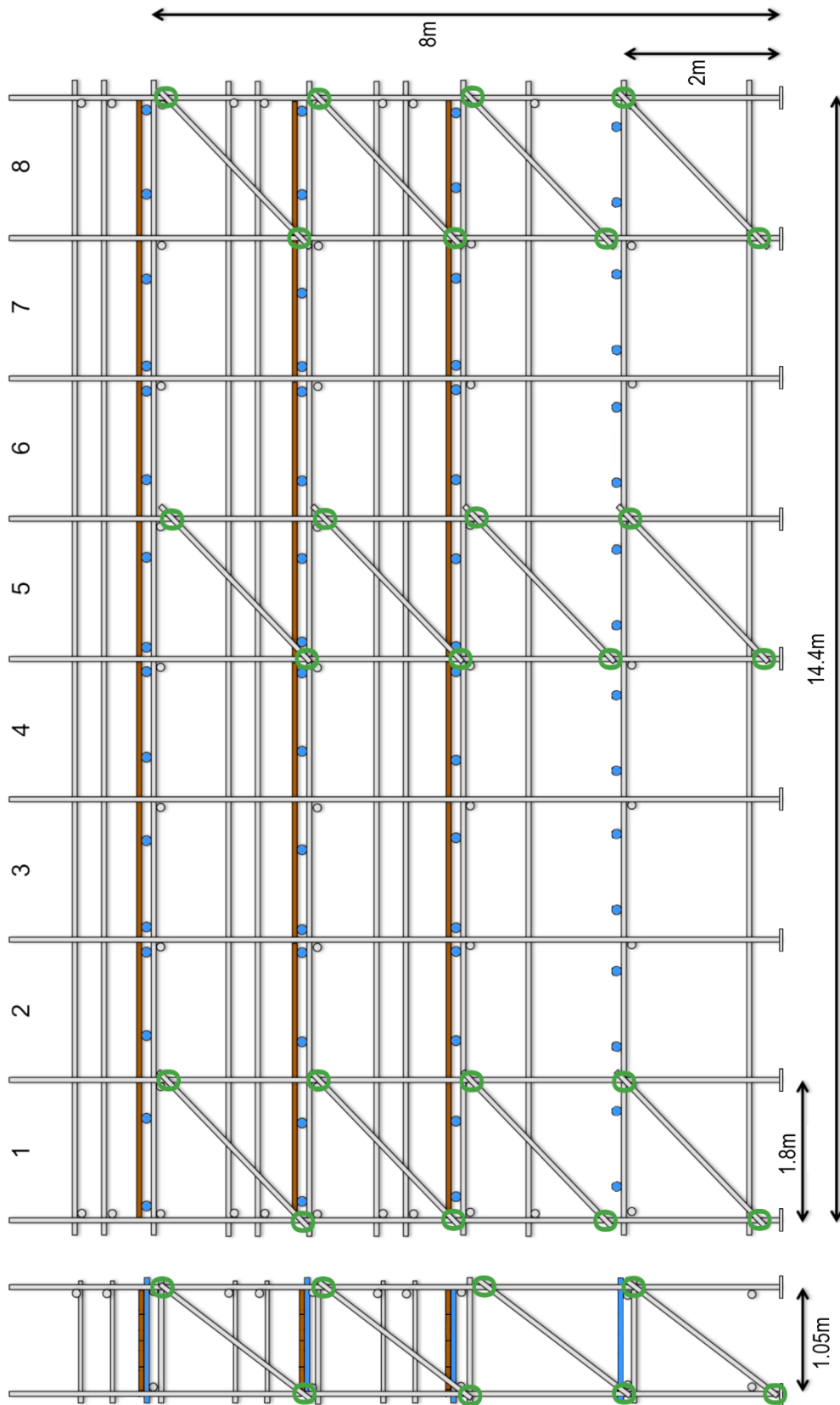

This drawing, combined with the site and job information provided will allow you to work out what parts and equipment you will need, and the quantities of each item to erect the scaffolding properly.

The table below lists the parts required for this particular scaffold:

Part	Quantity Required	Usage Notes
1.2m Scaffold tube	114	Used for transoms and putlogs.
1.5m Scaffold tube	6	Used for standards.
2.1m Scaffold tube	35	Used for standards and ledgers.
2.4m Scaffold tube	8	Used for transverse bracing.
2.7m Scaffold tube	12	Used for longitudinal bracing.
3.6m Scaffold tube	46	Used for standards and ledgers.
4.2m Scaffold tube	12	Used for standards.
5.4m Scaffold tube	17	Used for ledgers.
6.3m Scaffold tube	6	Used for standards.
2.7m Hardwood plank	6	Used for ladder access to working platforms.
3.6m Hardwood plank	42	Used for working platforms.
Right angle/fixed coupler	285	Used to secure transoms, ledger, putlogs (on non-working platforms), ties, guardrails and midrails.
Swivel coupler	40	Used to secure bracing.
Putlog coupler	96	Used to secure putlogs on working platforms.
Sleeve type end-to-end joiners	87	Used to join standards and ledgers.
Baseplates	18	Adjustable baseplates may be required depending on surface condition and grade.

Note: Additional components will be required depending on tie in methods used, and for edge protection around ladder access. Tie tubes must not be joined so adequate length tubes (or extended transoms) must be selected (depending on the configuration of the ties).

2.2 Identify, Select and Inspect Equipment



A scaffolding task may require the use of a wide range of scaffolding, associated and safety equipment to be used and installed.

Part of completing the planning for the scaffolding job is to identify what equipment you will need, then select and inspect that equipment to make sure it is safe for use.

It is very important that you check all equipment before you use it to ensure that it is safe to use and suitable for the task.

2.2.1 Identify, Select and Inspect Associated Equipment

The erection, alteration and dismantling of scaffolds requires you to use a range of associated equipment.

Associated equipment includes:

- Planks.
- Ladders and stairways.
- Scaffold tubes.
- Couplers and fittings.
- Fibre ropes and Flexible Steel Wire Rope (FSWR).
- Footings.
- Screening.
- Hand tools.





Check that all components are not damaged or worn. Check that all components fit together securely.

Suppliers of scaffolding need to provide written information providing instructions and information on required maintenance procedures.

Check the drawings and designs in any relevant planning documents and/or the manufacturer’s manual to make sure you have all of the parts you need.

2.2.1.1 Scaffold Planks

Planks are used to construct working platforms. They can be made of timber, aluminium or steel.

Planks should have the correct information displayed upon them.



The usual width of a scaffold plank is 225 mm. The usual thickness of a hardwood solid timber scaffold plank 32 mm.

Do not use scaffold planks with any of the following faults:

Possible Timber Plank Defects:	
Markings are missing, incomplete or illegible (refer to AS/NZS 1577).	End fixing is missing.
Width is less than 220mm.	Painted or treated which may conceal damage.
Thickness has been reduced by more than 10%.	Deep burns.
Laminations are separating in a laminated plank.	Deep oil stains causing the plank to be slippery.
Warped, twisted, broken, split or worn.	Nails projecting/any kind of rot.
End hoop iron is broken or damaged.	Knots present.

Possible Metal Plank Defects:	
Twisted.	Crushed.
Distorted.	Markings are missing.

End cap missing.	Width is less than 220mm.
Broken weld reinforcing strap.	

If any of these are present then the plank **MUST NOT BE USED!**

2.2.1.2 Ladders and Stairways



Ladders and stairways are used in addition to personnel hoists to access a scaffold.

If there is an emergency or mechanical breakdown, all workers on the scaffold need an alternate and safe means of exiting the scaffold; this includes ladders and personnel hoists.

The following ladders cannot be used to access a scaffold:

- A domestic grade (or non-industrial grade) ladder.
- A step-ladder.

A single industrial grade ladder or industrial grade extension ladder are the only types of ladders that may be used to access the scaffold.

It is vital that you only use ladders that are in good working order.

Possible Ladder Defects that will Condemn a Ladder from Being Used for Scaffolding Access:	
Timber stiles are warped, splintered, cracked or bruised.	Ropes, braces or brackets are missing, worn or broken.
Metal stiles are twisted, bent or kinked.	Tie rods are missing, broken or loose.
Crushed damaged welds or damaged feet.	Ladder is not industrial strength.
Rungs, steps, treads or top plates are missing, worn, damaged or loose.	Timber parts (apart from narrow identification bands) are covered with opaque paint or other treatment that could disguise faults.

If any of these are present then the ladder **MUST NOT BE USED!**

2.2.1.3 Scaffold Tubes, Tie Tubes and Fittings

Scaffold Tubes

Scaffold tubes may be made from aluminium or steel.

The minimum outside diameter of a common scaffold tube is 48mm.

The minimum wall thickness of a common steel scaffold tube is 4mm.



The minimum wall thickness of a common aluminium scaffold tube is 4.45mm (or 4.4mm or 4.5mm).

Possible Scaffold Tube Defects:	
Pitted.	Flame cut.
Bent.	Cross cut.
Split ends.	Mushroom headed.
Tube wall thickness less than minimum requirements.	Heavily corroded.

If any of these are present then the scaffold tube **MUST NOT BE USED!**

Tie Tubes



Tie tubes are used to fix a scaffold to the structure to provide support and stability. This keeps the scaffold erect, level and stable. Generally, they are connected to the scaffold using a right-angle coupler.

Check that they are not damaged or worn and that the scaffold tubes connect properly.

2.2.1.4 Couplers and Fittings

Couplers (or clips or fittings) are used to join two scaffold tubes. There are many different types of couplers including:



- **Right-angle coupler** – A non-swivel loadbearing coupler, other than a putlog coupler, that connects two tubes at right angles.
- **Swivel coupler** – A coupler used for connecting two tubes at any angle.
- **Putlog coupler** – A coupler for fixing a putlog to a ledger.
- **End-to-end coupler** – Internal expanding joint pin that connects and aligns the tube end-to-end.
- **Sleeve coupler** – An external end-to-end coupler for joining two tubes.
- **Parallel coupler** – A coupler for making a lap or spliced joint between two tubes.

End-to-end couplers must not be used in the following places:

- In horizontally or vertically adjacent ledgers in the same bay.
- In the same ledger in adjacent bays.
- More than once between adjacent standards.
- In the end bay of a scaffold.
- More than 300mm from a standard.





The following scaffold tubes may not be joined end-to-end:

- Ties.
- Transoms.
- Ledgers (if the join will occur within the end bay of a scaffold).

There are two methods of tightening a coupler:

- **Screw-tightened coupler** – A coupler in which the clamping force on the tubes is provided by tightening the flaps around the tube by means of a bolt and nut.
- **Wedge-tightened coupler** – A coupler in which the clamping force on the tubes is provided by tightening the flaps around the tube by means of a wedge



Possible Coupler Defects:	
Damaged hinges.	Damaged threads or nuts.
Excessive oil, grease or paint. hammered into place.	

If any of these are present then the coupler **MUST NOT BE USED!**

When couplers are used to prevent movement (as opposed to connecting scaffold tubes) they are referred to as 'check couplers' or 'safety couplers'. Check couplers may be a right angle coupler, swivel coupler or parallel coupler that is fixed hard up against a loadbearing coupler to increase the slip resistance along the tube.



Different configurations of scaffold tubes require check couplers to prevent unwanted movement and keep the scaffold stable and secure.

Check couplers should be positioned to prevent movement caused by compression or tension (depending on the configuration). You need to identify whether the affected tubes are in tension or compression.

The diagrams below show each of these situations and where the check couplers should be positioned.

Scaffold Tube (Brace) in Tension:

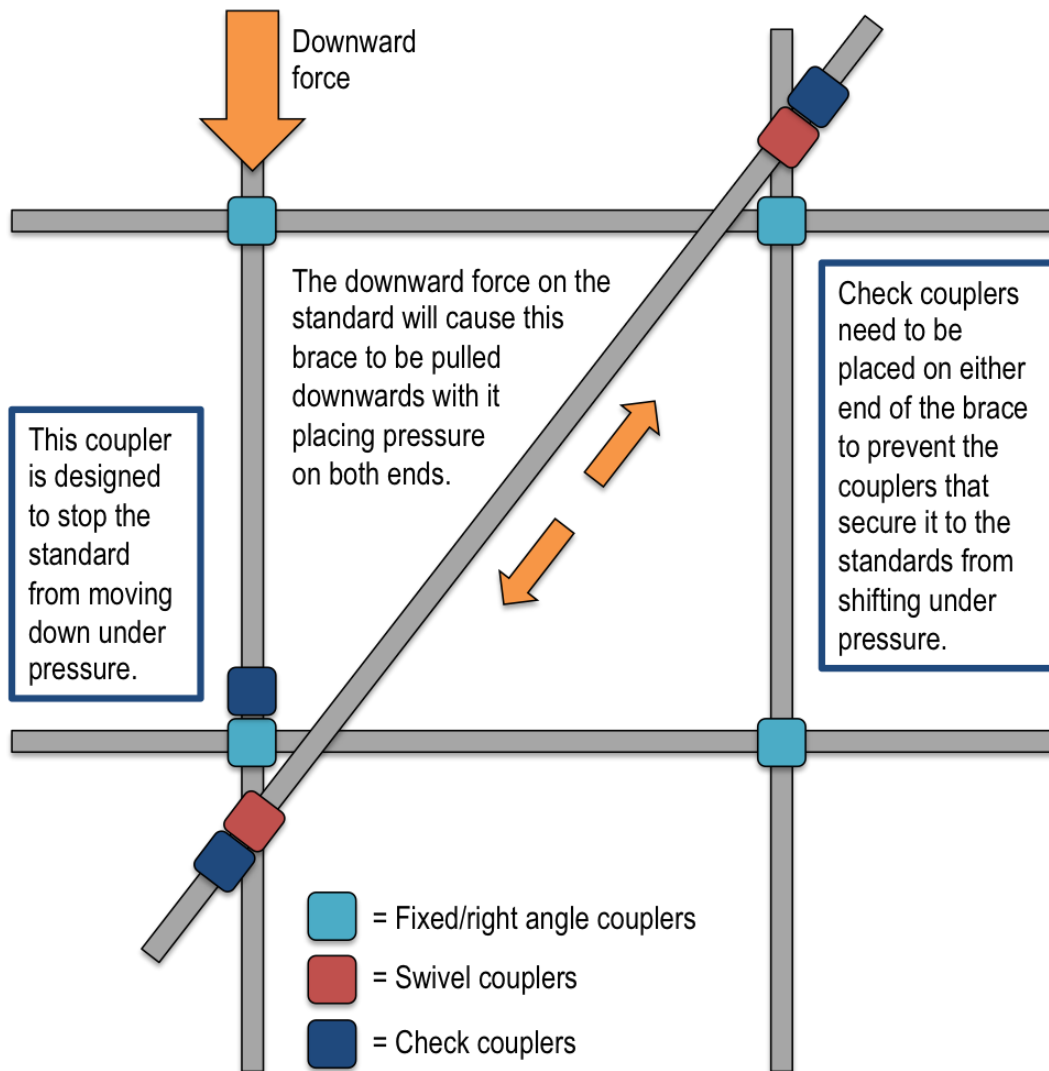

Scaffold Tube (Brace) in Compression:

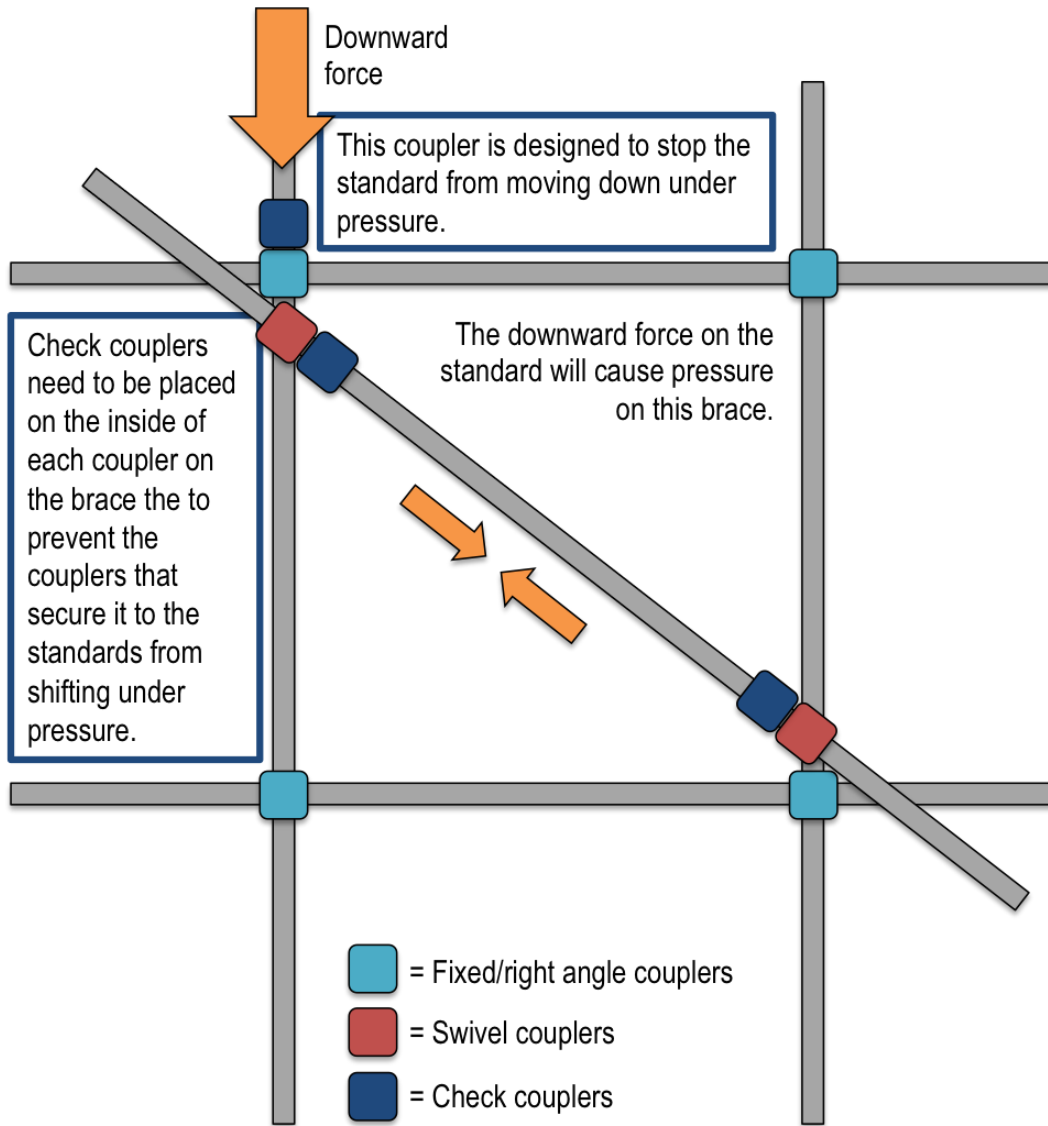

2.2.1.5 Footings

Footings provide a stable foundation for the scaffold and to prevent unwanted movement.

There are two main types of footing for a scaffold:

- Base plates.
- Adjustable base plates (screw jacks).

Depending on the ground conditions soleplate or sole boards may be used under the base plates to provide a more stable surface. Make sure the soleplates are strong and rigid enough to distribute the load.



The minimum size of a square baseplate is 225 cm² (150 mm x 150 mm) and it should be at least 6 mm thick.

The maximum extension on an adjustable baseplate is 600 mm.



The shank (unthreaded part) of an adjustable base plate should extend at least 150 mm, or 4 x the total length of the shank (whichever is greater) past the maximum extension. This is to ensure that there is enough of the shank sitting within the standard to keep the scaffold stable.

The maximum load to be placed on an adjustable base plate depends on the design of the scaffold.

U-Heads are a type of baseplate that may be used where a cantilevered scaffold is set up on beams or needles. U-Heads may also be adjustable.

Check all footings for damage or wear before use. Check that adjustable base plates wind and unwind smoothly and they are not bent or warped. Do not use any equipment that is faulty or damaged.

2.2.1.6 Fibre Ropes and FSWR

Fibre ropes can be used for lifting and temporarily securing components during the erection and dismantling of the scaffold.

The minimum diameter of fibre rope you would use for a hand line is 12 mm.

To determine the rated capacity of fibre rope use the formula:

$$\text{Rated Capacity} = D^2 \text{ (mm)}$$

OR

$$\text{Rated Capacity} = \text{Diameter (mm)} \times \text{Diameter (mm)}$$

You must check any fibrous ropes carefully before using them. The checklist below outlines what you are looking for. If a rope shows any of these it is unsuitable for use.

Possible Fibrous Rope Defects:	
Broken fibres/strands.	Stretched rope (overloading).
Excessive wear.	Abrasion.
High stranding.	Chemical exposure.
Brittleness.	Knots.
Sun rot.	Mildew.
Discolouration due to excessive heat.	

If any of these are present then the rope **MUST NOT BE USED!**

Flexible steel wire ropes (FSWR) are used for the termination of static lines and as guys for scaffolds.

To determine the rated capacity of FSWR use the formula:

Rated Capacity = D^2 (mm) x 8
 OR
Rated Capacity = Diameter (mm) x Diameter (mm) x 8

You must check any FSWR carefully before using it. The checklist below outlines what you are looking for. If a FSWR shows any of these then it is unsuitable for use.

Possible FSWR defects:	
Missing or illegible rated capacity markings.	Excessive number of broken wires.
Bird-caging (Strands loosened from proper tight lay).	Severe kinking or fractures from bending or reeving.
More than 10% wear in the rope diameter.	Crushed/damaged strands.
Splice, ferrule, eye or thimble damage.	Abrasion wear.
Squashed FSWR.	Stretched or overloaded FSWR.
Knotted FSWR.	Core collapse.
Severe/serious corrosion (indicated by loose and springy wires).	High stranding.
Chemical exposure.	High temperature exposure.

If any of these are present then the rope **MUST NOT BE USED!**

2.2.1.7 Screening



Sheeting or Screening is used to protect workers from environmental hazards such as dust and sunlight.

Do not use flammable material such as hessian for sheeting as these can introduce unnecessary hazards on site.

An engineer should always check the design of a sheeted scaffold prior to it being installed.

2.2.1.8 Adjustable Props

National Courses PTY LTD

Adjustable props are used to support temporary beams (needles) for cantilevered scaffolds and similar equipment, such as cantilevered crane loading platforms (CCLP).



Generally, adjustable props come with two mechanisms for adjustment:

1. A pin (sometimes called a prop or “G” pin) is used for coarse adjustments.
2. A threaded collar is used for fine adjustments.

Make sure that all parts move and lock properly and that the prop is rated for the job. If you are unsure check with the manufacturer.

2.2.1.9 Hand Tools



There are many different tools and maintenance equipment you can use for the various tasks needed to construct a scaffold.

It is important that you read the operators manual before using any equipment for the first time. This will ensure you use equipment safely and effectively to complete your work.

Some tools you may use whilst completing scaffolding work include:

- Box spanner.
- Podgers.
- Wrenches.
- Cutters.
- Wire nips.
- Hammers.
- Tape measure.
- Sledge hammers.
- Hammer drills.
- Shovels.
- Wheelbarrows.
- Spirit and torpedo levels.
- Spanners and box spanners.



A scaffold belt can be used to carry hand tools while working.

All tools and equipment used for the erection, alteration and dismantling of scaffolds must be used in accordance with the manufacturer's specifications, organisational policies and procedures and safe work practices.

Do not exceed the limitations of the equipment – it could be extremely dangerous and could damage the equipment.

Always check that all tools and equipment are functioning correctly and that they do not show any signs of damage or wear.

2.2.2 Identify, Select and Inspect Scaffolding Equipment

Scaffolding equipment is made up of the equipment that is used with the scaffold while the scaffold is in use. This equipment is often installed once the scaffold is in place, or during the erection process.

Scaffolding equipment includes:



- Basic level equipment:
 - Materials hoists.
 - Gin wheels.
 - Static lines.
 - Safety nets.

- Intermediate level equipment:
 - Mast climbers.
 - Perimeter safety screens and shutters.
 - Cantilevered crane loading platforms.

2.2.2.1 Mast Climbers

Mast climbers are made up of work platforms. These work platforms can be that are raised and lowered along 1 or more masts using a hoist mechanism.

Mast climbers may need to be tied to a building under circumstances prescribed by the manufacturer to make sure they remain stable during use.

Mast climbers are generally not suitable for use if the profile of a structure changes at different elevations (e.g. if the upper floors of a building 'step' back or balconies extend from the building).

Mast climbers should be inspected in accordance with site procedures and manufacturer's instructions before use.

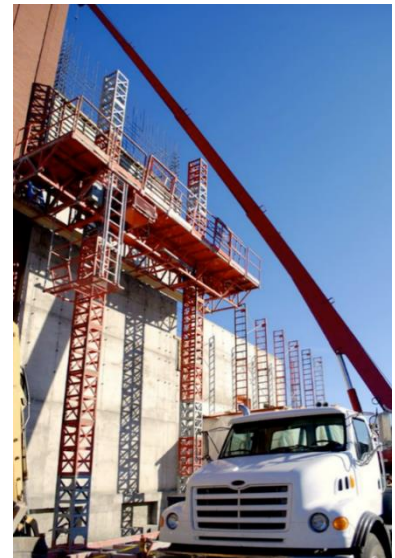

The erection and dismantling of mast climbing work platforms must be carried out, or be directly supervised, by a person holding an appropriate high risk work rigging or scaffolding licence.

Further information on mast climbing work platforms is provided in AS 2550.16 Cranes – Safe Use – Mast climbing work platforms.

2.2.2.2 Perimeter Safety Screens and Shutters



Safety screens generally extend one floor above the floor they are installed on.

The top of the screen should be high enough to provide edge protection for the floor that is to be built before any personnel can gain access to it.

2.2.2.3 Cantilevered Crane Loading Platforms



Cantilevered Crane Loading Platforms (CCLPs) are used to place loads with a crane into work areas high up off the ground.

A structural engineer or a person who is competent in the design of scaffolding should be consulted about the design and installation of a CCLP.

2.2.3 Identify Safety Equipment Requirements

Depending on the requirements of the job, you may need to use safety equipment to reduce the risk to an acceptable level.

Safety equipment includes:

- Safety harness.
- PPE.
- Lanyard.
- Energy absorber.
- Inertia reel.



All safety equipment should be selected at the planning stage.

Safety equipment needs to be inspected before and after use.

2.2.3.1 Safety Harnesses



In most cases of working at heights a full body harness should be worn. Harnesses must:

- Be correctly fitted in accordance with manufacturer's instructions to ensure effectiveness.
- Meet the requirements of AS/NZS 1891 Industrial fall-arrest systems and devices.

Workers should connect the fall-arrest line to the attachment point on their harness (dorsal attachment point in the middle of the back, or the chest connection) that will provide the best protection in the situation it is being used.

A fall-arrest harness must be inspected before use.

Shown here are some examples of things you need to check the harness for:

Component	Condition/Fault to be Checked
Webbing	<ul style="list-style-type: none"> ● Cuts or tears. ● Abrasion damage. ● Excessive stretching. ● Damage due to contact with heat, corrosives or solvents. ● Deterioration due to rotting, mildew, or ultraviolet exposure.
Snap Hooks	<ul style="list-style-type: none"> ● Distortion of hook or latch. ● Cracks or forging folds. ● Wear at swivels and latch pivot pin. ● Open rollers. ● Free movement of the latch over its full travel. ● Broken, weak or misplaced latch springs (compare if possible with a new snap hook). ● Free from dirt or other obstructions, e.g. rust.
D-rings	<ul style="list-style-type: none"> ● Excessive 'vertical' movement of the straight portion of the D-ring at its attachment point of the belt, so that the corners between the straight and curved sections of the D become completely exposed. <p>NOTE: Excessive vertical movements of the D-ring in its mounting can allow the nose of larger snap hooks to become lodged behind the straight portion of the D, in which position the snap hook can often accidentally 'roll out' of the D under load.</p> <ul style="list-style-type: none"> ● Cracks, especially at the intersection of the straight and curved portions. ● Distortion or other physical damage of the D-ring. ● Excessive loss of cross-section due to wear.
Buckles and adjusters	<ul style="list-style-type: none"> ● Distortion or other physical damage. ● Cracks and forging laps where applicable. ● Bent tongues. ● Open rollers.

Stitching	<ul style="list-style-type: none">● Broken, cut or worn threads.● Damage or weakening of threads due to contact with heat, corrosives, solvents or mildew.
------------------	---

2.2.3.2 Lanyards and Energy Absorbers

Lanyards are used to stop tools falling from heights. These lanyards are connected to the tool and wrap around the wrist or belt of the scaffolder.

To reduce injuries caused by a fall, energy absorbers should be used as part of the fall arrest system.



The energy absorber should restrict the fall distance to a maximum of 2 metres before the fall-arrest system takes effect.

There should be a minimum of slack in the fall-arrest lanyard between you and the anchor point, which should be as high as the equipment permits.

Avoid work above the anchor point, as this will increase the free fall distance in the event of a fall. This would result in higher forces on the body and greater likelihood of the energy absorber snagging on obstructions.

2.2.3.3 Inertia Reels

National Courses PTY LTD

Inertia reels limit the potential fall distance for someone working at heights whilst providing a worker with a relatively free range of movement or extra reach compared to a lanyard. These have the added safety feature of being able to lock in the event of a fall, arresting the descent of the worker.

Inertia reels must comply with AS 1891.3 Fall-arrest devices.

Inertia reels should not be used in the following situations:

- While working on a sloped surface (e.g., a steeply pitched roof) or any other surface where a fall may not be a quick vertical one.
- Locked as a constant support for a worker during normal work.
- In conjunction with a lanyard.



Shown here are some examples of some things you need to check an inertia reel for:

Component	Condition/Fault to be Checked
Rope (Fully Extend Rewind Drum Anchorages)	<ul style="list-style-type: none"> ● Cuts. ● Abrasions or fraying. ● Stretching. ● Damage due to contact with heat, corrosives, or solvents. ● Excessive dirt or grease impregnation. ● Check that the rope end is securely anchored to the drum.
Anchorage Body	<p>a) Mountain ring:</p> <ul style="list-style-type: none"> ● Physical damage or wear. ● Cracks. ● Mounting security. <p>b) Anchorages body proper:</p> <ul style="list-style-type: none"> ● Physical damage. ● Check for the entry of foreign bodies. ● Loose or missing screws, nuts or similar objects. ● Position of the clutch compression indicator button.
Locking Mechanisms and Rope Guides	<ul style="list-style-type: none"> ● Check rope guides for excessive wear or ridging. ● Check that the rope-locking mechanism locks and holds securely. ● Ensure that the rope runs freely through the anchorage, and that on rewind drum anchorages the rope rewinds completely without loss of tension.
Hardware	<ul style="list-style-type: none"> ● Examine the condition and locking action of any associated snap hooks or links.

2.3 Work Site Communication

You should always communicate with those around you while you work. Make sure you understand any instructions given to you.



Communication procedures can be found in:

- Manufacturer's guidelines (instructions, specifications, checklists).
- Industry operating procedures and relevant codes practice.
- Workplace procedures (work instructions, operating procedures, checklists).
- Reporting and recording procedures (equipment defect/s).

Following these procedures will ensure that everyone clearly understands what their tasks are on site and how do complete them safely.

2.3.1 Communication Methods

Talk to the appropriate personnel (e.g. supervisors, colleagues or managers) to discuss the best methods for communication while you are still at the planning stage of the job.

Workplace communications may take the form of:

- Verbal and non-verbal language.
- Written instructions.
- Signage.
- Hand signals.
- Listening.
- Questioning to confirm understanding, and appropriate worksite protocol.
- Toolbox meetings.



Reaching an agreement with other personnel on site about the best communication methods is important. It will make sure everyone knows what is expected of them when they are communicating or receiving to information.

These expectations can be communicated during the work site induction process or found in policies and procedures.

2.3.2 Select and Inspect Communications Equipment



Most worksites use two-way radios for communication. The two types of two-way radio are conventional and fixed channel.

It is important that two-way radio systems provide clear signals without any interference on the channel.

Inspect all equipment before you start the job for faults or defects and proper functioning. Doing this will make sure equipment is working properly and that you can communicate with other workers clearly (without interference).

Do not use any communication equipment that is not consistently working properly.

2.3.2.1 Conventional Radio

National Courses PTY LTD

Great care must be taken when allocating frequencies/channels to make sure that there are no other operators using the same frequency in the area.

Interference on your frequency can be a safety hazard. Stop work until the radio is checked or a new frequency selected and allocated.



2.3.2.2 Fixed Channel Radio



Fixed channel radio is a computer controlled two-way system that locks other radio users out of your selected frequency.

With a fixed channel radio it is possible to have several separate groups on one site communicating by radio without interfering with each other.

This radio is recommended for large sites.

2.4 Defective Equipment

If you identify any equipment that is defective, damaged or faulty you must not use it. Doing so could risk the safety of yourself or others on site.

If you are unsure of if the equipment is defective, consult with your supervisor or manager for guidance.



2.4.1 Isolate Defective Equipment

Defective equipment needs to be isolated from use to stop anybody from accidentally using it. The defect then needs to be reported to an authorised person as soon as practicable.

Your worksite will have isolation procedures for defective equipment you must follow. This may include tagging or locking out equipment and completing fault reports or other documentation.



Faulty equipment may need to be labelled and rejected, destroyed or returned to the manufacturer for repair (depending on the type and severity of the fault).

Scaffolding components that are identified as faulty or unsafe must be tagged and removed from site.

2.5 Set Up for the Task

Once you have selected all of the equipment you will need and made sure it is safe to use you will need to start setting up for the task.

Planning and preparation are essential to conducting the work safely and on schedule.

This includes:

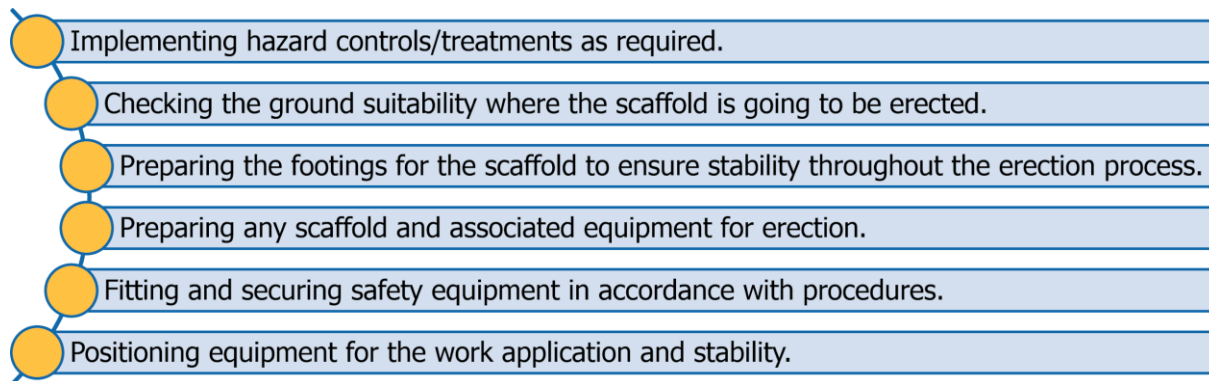
- 
- Implementing hazard controls/treatments as required.
 - Checking the ground suitability where the scaffold is going to be erected.
 - Preparing the footings for the scaffold to ensure stability throughout the erection process.
 - Preparing any scaffold and associated equipment for erection.
 - Fitting and securing safety equipment in accordance with procedures.
 - Positioning equipment for the work application and stability.

2.5.1 Implement Hazard Controls

Once you are ready to start setting up the scaffold make sure you have implemented the necessary hazard control measures.

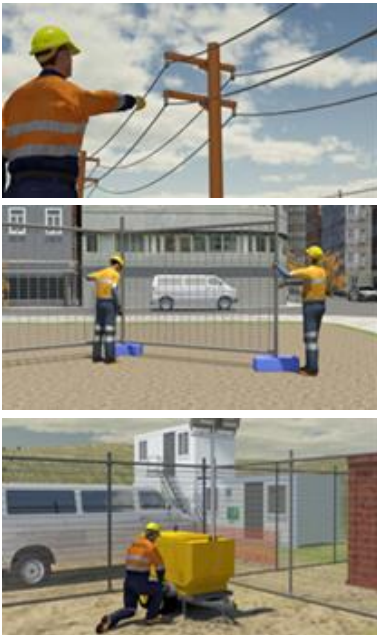

Hazard prevention/control measures may include:

- Power disconnected by competent authority (where applicable).
- Safe and adequate access and egress (entry and exit).
- Safety tags on electrical switches and isolators.
- Safety observer (spotter) inside an exclusion zone (e.g. electric/power lines).
- Power line warning systems (e.g. Tiger tails).
- Setting up barricades and traffic control to keep the area clear.
- Pedestrian control (barricades, signs, etc.) to limit the number of people in the area.
- Moving any obstructions out of the way.
- Setting up adequate lighting in the work area.

Be aware that hazard controls you implement may interfere with the work of others on site. Consult with other workers impacted by hazard controls to make sure they are aware of the control measures you plan to use and how it may impact their activities.

Some hazards are caused by the work being done so you may need to implement hazard controls before the work begins. Make sure to move obstructions such as equipment, materials or debris, or install trench covers if working near excavations.

Always wear the required PPE for the job. Make sure that any control measures are consistent with workplace and safety standards. If you are unsure, check with your WHS officer or supervisor.

2.5.2 Check Ground Suitability

You will need to establish the suitability and capacity of the ground before setting up the scaffold. Make sure the scaffolding tasks are conducted on a firm surface capable of supporting the structure or task in a safe manner.

Different ground conditions and soil types can have an effect on the stability of a scaffold construction. You should check if the ground is rough, uneven, or soft as this could cause the scaffold or equipment to unstable during operation.

Backfilled trenches may not have compacted completely and are dangerous to set up the equipment on.

If the ground is uneven then materials may need to be added or removed to fix this. Doing this is called levelling. This will require specialised equipment, personnel expertise, and calculations.

You also need to determine if a larger or more suitable base is required for the scaffold and equipment erection

The pressure of the equipment could cause damage to the underground services/pipes/cables.

For this reason, it is important to make sure there are no underground services running through the area where you plan to set up.

If you are unsure about the load bearing capacity of the ground refer to a soil report from a competent person such as an engineer with experience in scaffolding structural design/analysis and knowledge of the relevant Australian Standards (such as AS 1576).



You must also check the load bearing limits of suspended concrete floors, building roofs and landings if loads, scaffolds or equipment is going to be resting on them.

To make sure the ground is strong, firm and level enough to keep the scaffold erect, level (horizontally straight), plumb (vertically straight) and stable you need to know 2 things:

- The weight of the scaffold.
- The load bearing ability of the ground.

To work out the dead load weight of the scaffold, add the weight of all components resting on each baseplate (including the weight of the baseplate itself).

To do this add:

Dead Load Weight

- = The weight of the baseplate.
- + The weight of the standards.
- + 1/2 the weight of any transoms connected to the standards.
- + 1/2 the weight of any ledgers connected to the standards.
- + 1/2 the weight of each brace connected to the standards.
- + 1/4 of the weight of all planks supported by the standards.

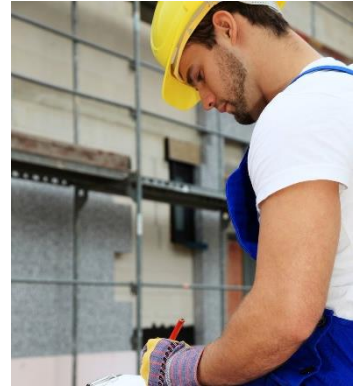

You will need to check with the manufacturer for the specific weights of all scaffold components that you are using.

Tubes may vary in weight between 1.5kg – 5kg per metre depending on what they are made from (e.g. aluminium or steel) and the thickness of the tube walls.

2.5.3 Prepare Footings and Foundations

A scaffold must have a firm footing to keep it stable and secure.

Sole plates/boards and base plate or screw jacks are used to provide a secure foundation.



The size of a sole plate depends on the combined dead load, and the live load weights.



To work out how long these need to be you need to know the total weight that will be placed on the specific sole plate and the weight bearing ability of the ground you are setting up on.

To work this out add the dead load to the live load (the live load is calculated as 1/4 of the scaffold duty per platform, per bay) and divide the answer you get by the load bearing pressure (measured in kg/m²), then divide this answer by the width of the sole plate to determine the required length of the sole plate.

2.5.4 Fit Safety Equipment

All safety equipment needs to be fitted before starting the scaffolding work. You need to make sure it is appropriate for the task and that it fits you correctly.



Never begin a scaffolding task without the appropriate safety equipment.

Safety systems (such as static lines) and working at heights where there is a chance of falls, require the use of a full body fall-arrest harness and installed anchor points.

Safety equipment also includes Personal Protective Equipment (PPE). Always make sure you are wearing the correct PPE for the task and worksite.



Generally at a minimum this would include:

- Hard hat or safety helmet.
- Safety gloves.
- Steel-capped work boots.
- High-visibility clothing.

Check for signage on site or talk to a manager or supervisor if you are unsure of the PPE requirements for the site.

2.5.5 Prepare and Position Scaffolding Equipment

All equipment and scaffolding needs to be prepared in line with site procedures, the scaffolding plan and the manufacturer's specifications before you start the work.



Any equipment and plant that you will be using throughout the scaffolding work needs to be correctly and safely positioned. This could include positioning plant and equipment or moving scaffolding components into position where it can be safely accessed.

It also includes coordinating resources so that you have everything that you need in or close to the work area.

This will allow you to erect the scaffold and equipment without having to continuously leave the work area, or disrupt operations that may be taking place elsewhere on the worksite.

3.1 Erect Scaffold and Scaffold Equipment



Erecting a scaffold and scaffold equipment requires careful planning, knowledge of equipment and procedures, accurate site information and good communication skills.

Equipment should be unloaded as close as possible to the work area and arranged in a logical order.

An engineer will also need to be consulted with in determining the weight bearing capacity of the surface the scaffold will be erected on compared to the size and weight of the scaffold.

3.1.1 Erecting a Tube and Coupler Scaffold

An example of a typical scaffold erection could be:

1. Place two baseplates on the supporting surface.
2. Place two standards on the baseplates.
3. Fix a transom to the lower parts of the standards at the required height.
4. Fix two ledgers at the base of the standards at 90 degrees to the transoms.
5. Place two more standards on two more baseplates and fix to the other end of the ledgers.
6. Fix transoms to the upper parts of the standards at the required height.
7. Fix two ledgers at the top of the standards at 90 degrees to the transoms.
8. Check that the structure is stable – adjust the level of tubes as required.
9. Continue this process to create the required number of bays.
10. Fix putlogs in position to create working platforms.
11. Place planks on the putlogs to create a safe working surface to erect the next lift.
12. Install appropriate access (e.g., ladder or stairway).
13. Repeat steps 2 – 11 to create the second lift.
14. Install handrails, guardrails and toeboards where required as you create working platforms.
15. Fix diagonal bracing with swivel couplers.
16. Fix ties to the scaffold in the appropriate positions.
17. Install safety screens as required by the scaffold design.

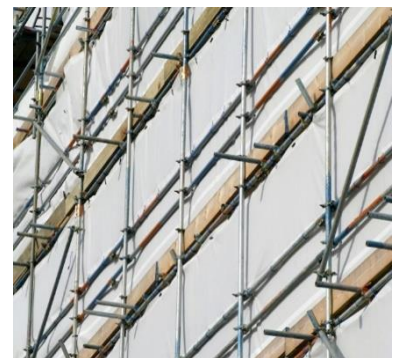

While erecting scaffolding it is important to make sure that:



- Standards, transoms, ledgers, putlogs, braces, and ties are positioned and fixed correctly.
- Scaffold is squared, level and plumb.
- Safety screens, toeboards, guardrails and midrails are fixed.
- Ladder positioned correctly and fixed.
- Scaffold matches the drawing or plans.

If an uncompleted scaffold must be left overnight you must remove all access to the scaffold and isolate or barricade off the area. Use signage and physical barriers to prevent unauthorised access to the scaffold. Signage and tags should also be added to the scaffold to indicate that it is incomplete and should not be used.



3.1.1.1 Tube and Coupler Scaffold Requirements

Tube and coupler scaffold requirements:



- Make sure the scaffold is not higher than 33m.
- Make sure you do not make the bay lengths too wide or too long for the duty of the scaffold. The bay of a single-pole scaffold should be no more than 1.8 metres long.
- The lift height of an independent scaffold should be no more than 2 metres (3 metres if double standards are used).
- Make sure you measure the correct positions on scaffold tubes where couplers are to be placed. Mark clearly where the couplers are to be placed showing which side of the line they are to be aligned.
- Make sure couplers are square and placed the right way up. Always use compatible couplers in the same lift.
- Make sure all transoms, ledgers, guardrails, midrails and braces are fixed firmly and in their correct positions.
- If braces need to be joined use a lapping or splicing technique.
- Toeboards should be fixed to standards with a gap of no more than 10mm. Where equipment or materials are stacked to a height that is above the height of the toeboard a guardrail, toeboard, mesh, containment sheeting, brick guards and infill panels are required for edge protection.
- Make sure a tube and coupler scaffold does not carry too many platforms. For example, a 33m high medium duty scaffold can carry four full length platforms if made of steel tubes but only two if made of aluminium tubes. A 20m high steel tube scaffold should have no more than 5 platforms.

3.1.1.2 Platform Requirements

Platform planks should all be the same thickness. They should be secured using cleating, plank straps or be lashed securely using a spliced eye or clove hitch with half hitches around the putlogs. Planks may be lapped at the returns of the scaffold, when there is a change in direction, on hanging bracket scaffolds, to cover gaps around corners or to match irregular building profiles.



The slope of a platform should be at an angle of no more than 3 degrees in all directions.

Platform planks should be placed close together and overhang putlogs no less than 150mm and no more than 250mm.

Where bay widths are not fully covered by the planks (e.g. on a birdcage type scaffold) you may use a structural plywood as an underlay to the platform planks where gaps are up to 150mm wide.

It is important that there is enough space on the work platform for the tasks that need to be carried out. Make sure there is enough clear access on all working platforms:

Situation	Minimum Clear Access on Work Platform
Non-Working Access Platform	450mm
Workers Using Hand Tools	450mm
Workers and Materials	675mm

3.1.2 Erecting a Cantilevered Scaffold



Cantilevered scaffolds are set up on cantilevered steel members called 'needles'.

A steel beam used as a needle for a cantilevered scaffold should be at least 75mm wide. It should be positioned so that 75% or $\frac{3}{4}$ of its length is 'inboard' and supporting the cantilevered section known as 'outboard'.

Cast-in inserts, through bolting and propping can be used to fix the inboard end of a cantilevered scaffold needle.

Anchorage bolts should have lock nuts to stop them from loosening. Anchorage bolts should be at least 15mm in diameter at the inboard end of a needle (do not use drilled-in anchors).

The first lift of ledgers and transoms on a cantilevered scaffold should be as close as possible to the needles.

Where putlogs are cantilevered to support extra planks, the minimum bay width of the supporting scaffold is no less than 950mm.



The cantilevered portion of putlogs can be supported by two 225mm planks.

When erecting a two plank wide cantilevered platform, make sure that the transom beneath the cantilevered scaffold extends far enough to support an extra ledger on the working face. Connect putlogs to all three ledgers using putlog clips.

The scaffold should be tied to the building at the first lift.

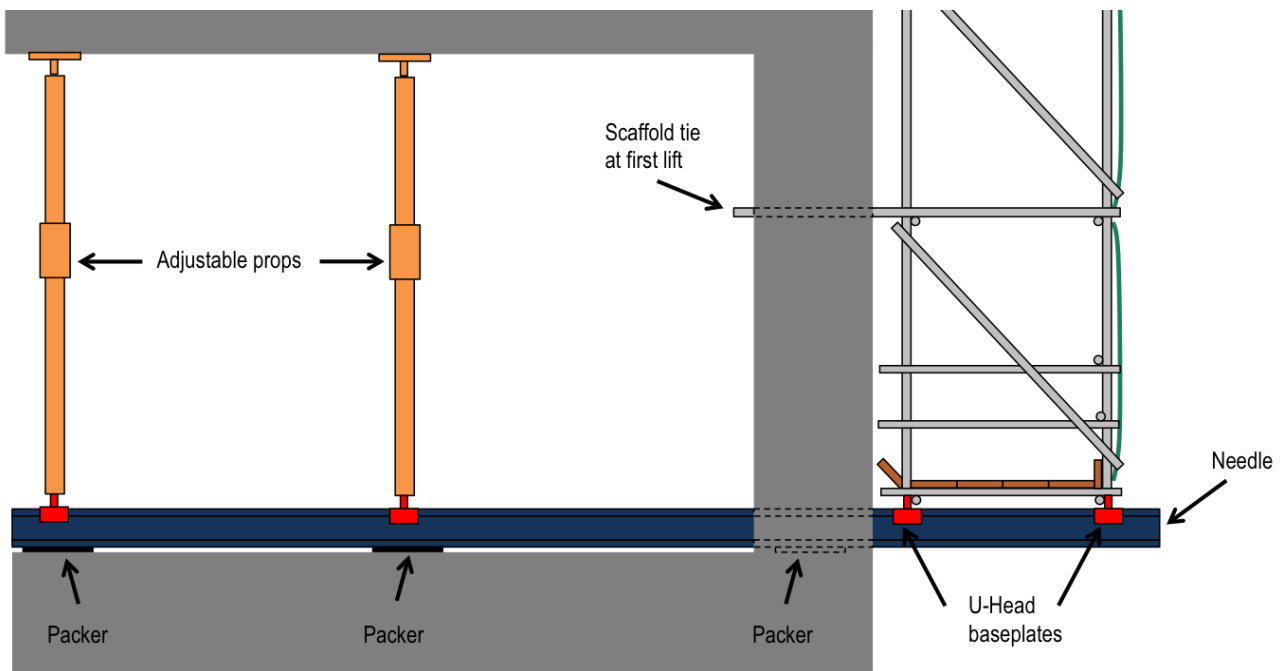

3.1.3 Erecting a Spurred Scaffold

Spurred scaffolds may be used where the conditions make it unfeasible to erect a cantilevered scaffold, or a scaffold that is erected from the ground.

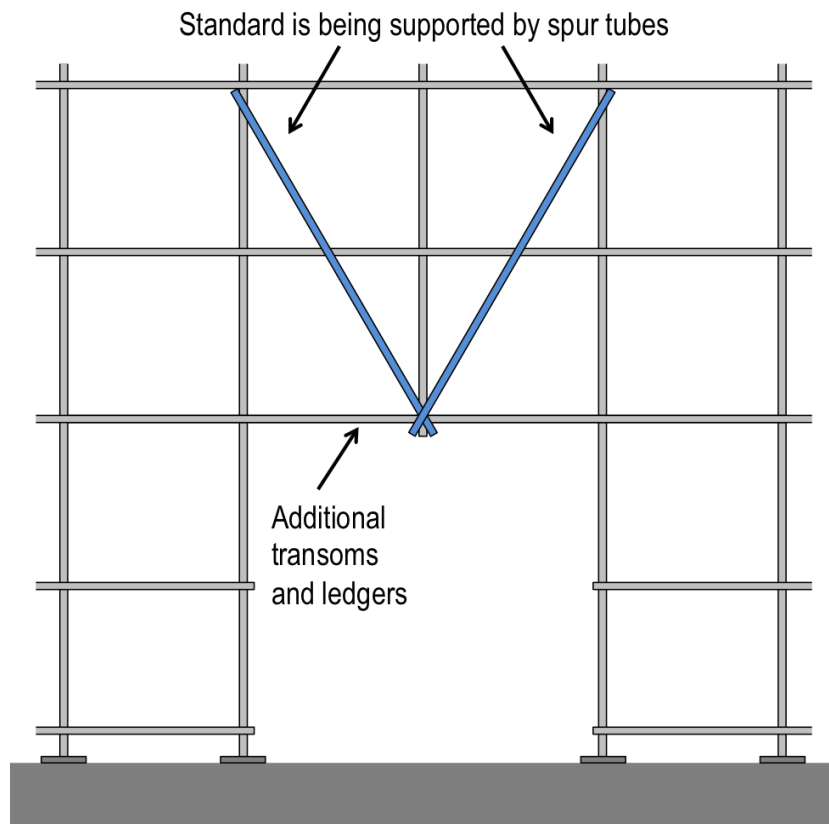

When erecting a spurred scaffold:

- A single set of spurs can support up to five lifts.
- Use a right angle coupler and a check coupler to fix a spur to a scaffold framework.
- A spur should be fixed at an angle of no more than 45 degrees from the vertical.

3.1.4 Erecting a Barrow Ramp or Sloping Platform

Barrow ramps and sloping scaffolds are designed to allow you to safely and easily access low level working platforms with wheeled equipment (such as a wheelbarrow).

All barrow ramps and sloping scaffolds must conform to the following standards:

- If installing cleats they should be 450mm apart with a 100mm gap (or the width of the tyre of the barrow being used) between them for the wheel of a barrow.
- The lower ends of sloping ledgers should be placed on soleplates.



- Sloping guardrails and midrails should be fixed to standards with swivel couplers so that they match the slope of the platform (providing the best possible protection).
- Cleats and lashing are both acceptable methods of preventing 'plank creep' on a sloping platform. Cleats may be fixed to the underside of the plank hard against the putlog, or the planks may be lashed directly to the putlog.

3.1.5 Ties

Ties are used to maintain the stability of the scaffold by preventing unwanted inward or outward movement.

There are 5 basic configurations that can be used to secure the tie to the structure or building:

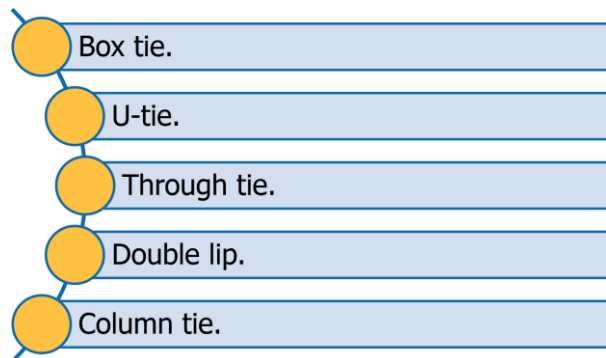

The method you select will be determined by the building or structure that the scaffold is being tied to.

3.1.5.1 Box Tie

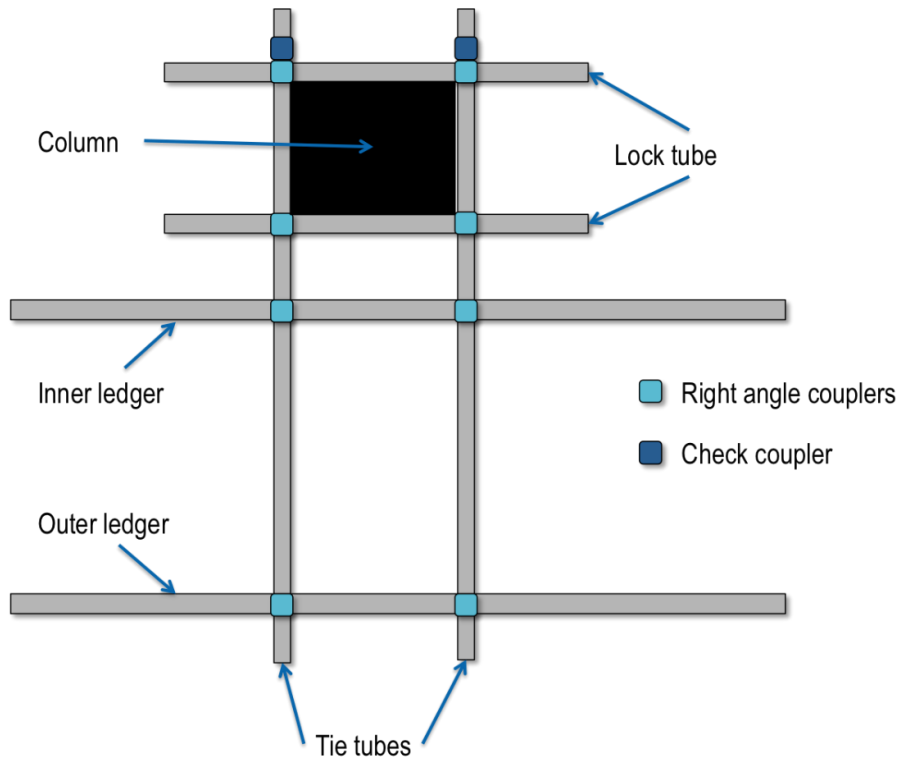

3.1.5.2 U-tie

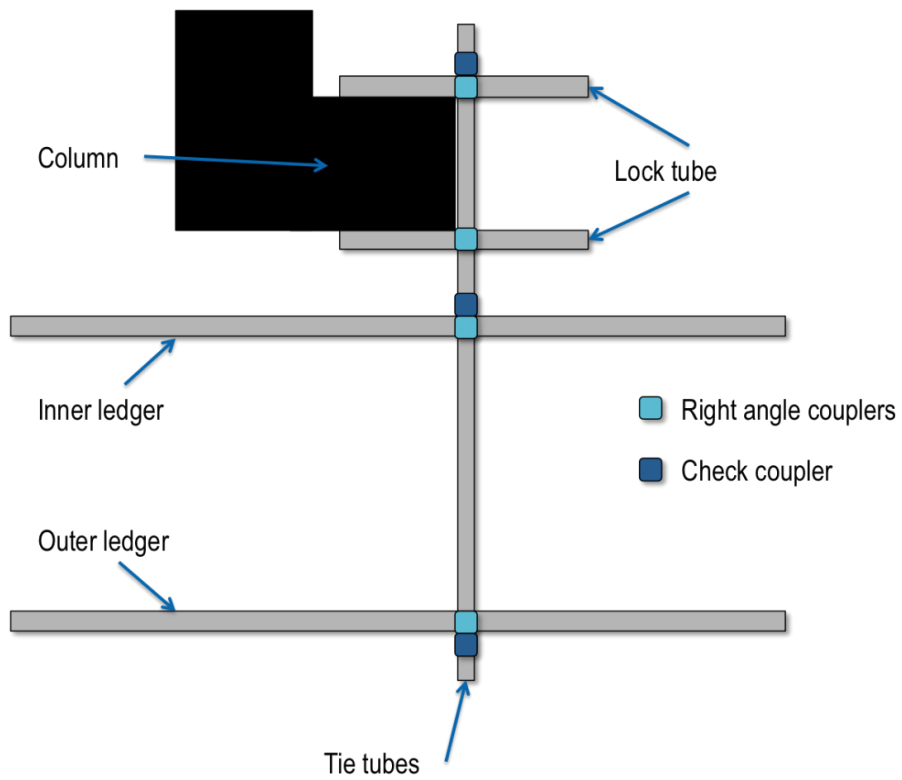

3.1.5.3 Through Tie

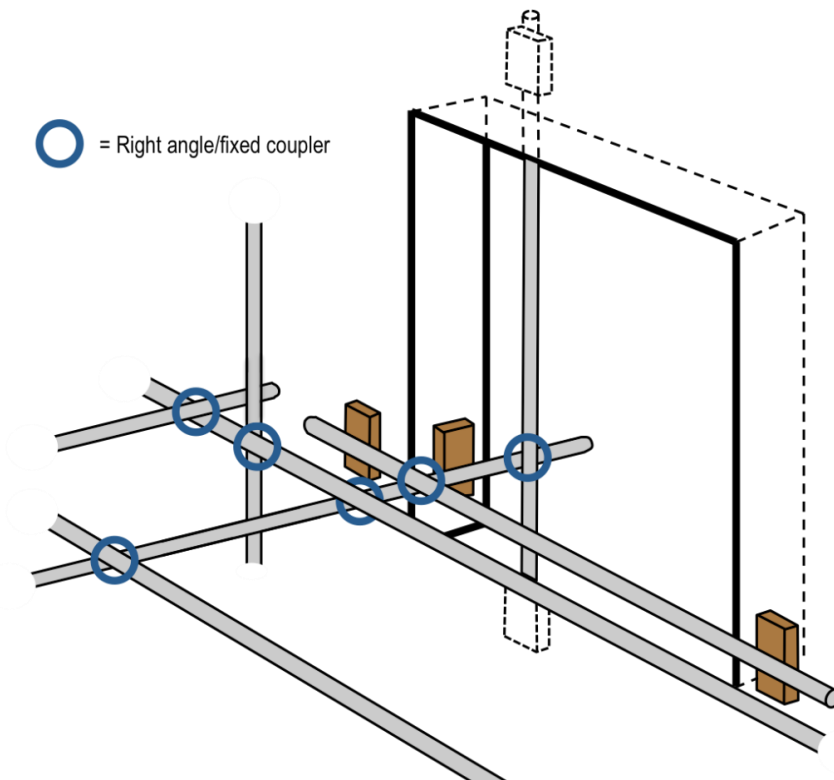

3.1.5.4 Double Lip

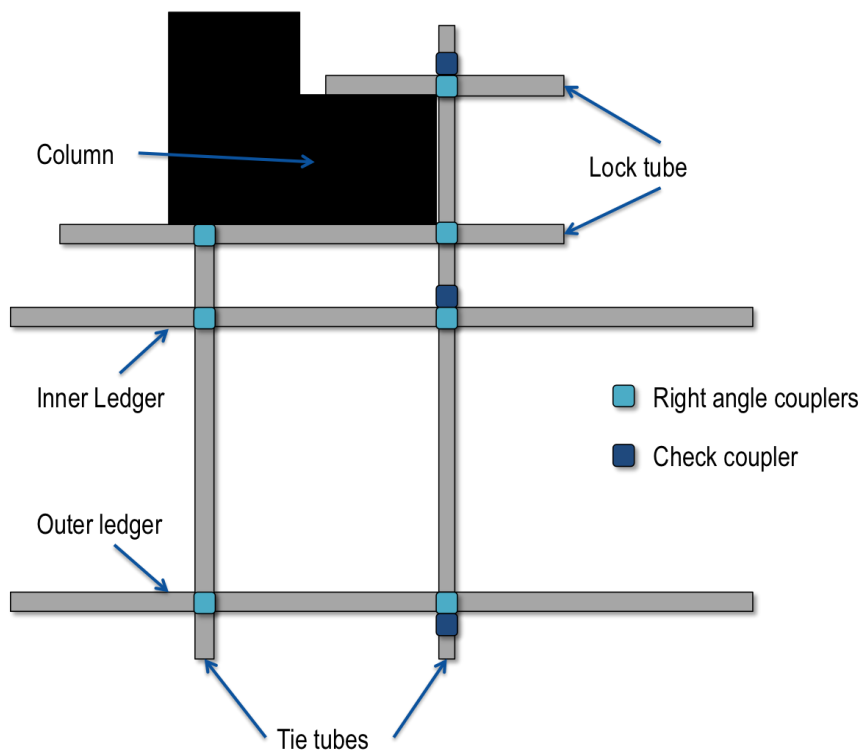

3.1.5.5 Column Tie

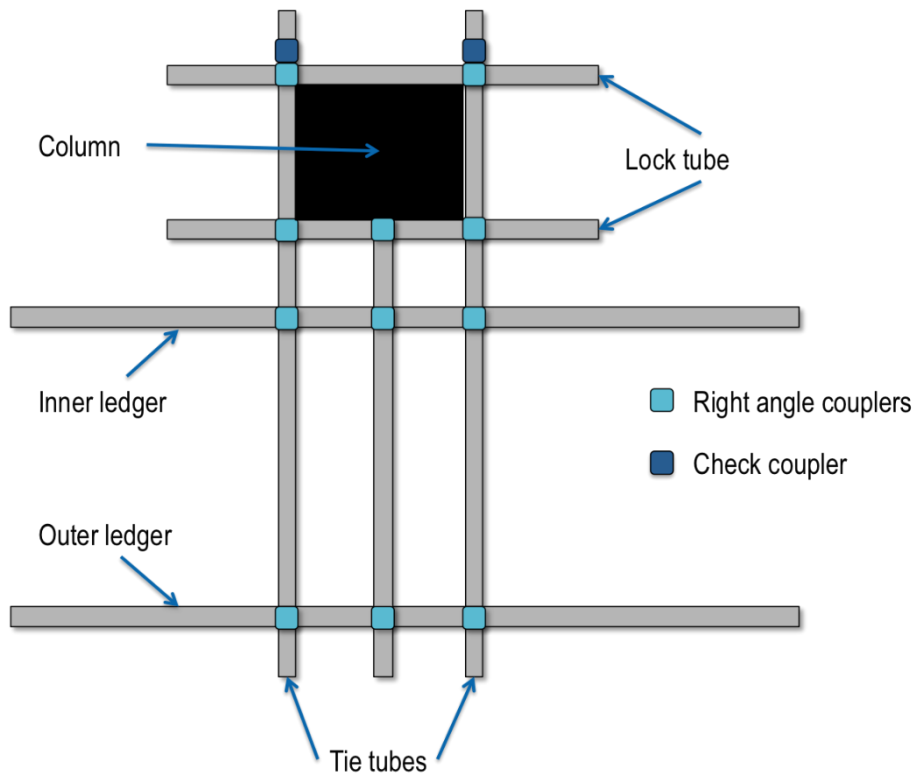

3.1.6 Work Safely at Heights



Working at heights includes any situation where a worker, or other nearby person, is exposed to a risk of falling (from one level to another) that is likely to cause injury to the worker or person.

All work at heights should include the use of safety equipment to prevent hazards such as personnel and materials falling from a height.

To minimise the risk of falling tools and equipment use appropriate manual handling techniques when carrying out work tasks. Pass, receive and position components safely and confidently.

All hand tools should be securely stowed on a belt to maintain the safety of all personnel.

When using handlines you should keep your back straight, your knees slightly bent and your feet placed firmly on a ledger. Use the standard as an anchor for your body.



Communicate effectively with other workers, this will allow you to co-ordinate with others on site to ensure safety for all personnel and the effective completion of the scaffolding tasks.

Do not ever work on the open framework of a scaffold without fall protection systems in place. Guardrails and midrails should be installed on working platforms as soon as possible during the erection and dismantling of scaffolds.

The area below the work should be barricaded or fenced off to prevent unauthorised access by other workers or the general public. Where this is not possible, it may be necessary to install overhead protection decks such as:



- Temporary gantries.
- Covered ways.
- Cantilevered catch platforms.
- Perimeter safety screens.
- Debris/safety nets.

Check access from ground to the work area (where applicable) to make sure it is safe, free of obstructions and meets all safety and work requirements.

Make sure that the work area is kept clean and tidy.

Rubbish should be removed regularly in a safe manner. Do not throw rubbish from the work area to the ground and keep access ways clear of materials, tools and equipment.



3.1.6.1 Monitor Work Area and Equipment

You should regularly monitor the work area for changing conditions or new potential hazards. Periodically check all equipment during work to ensure that it remains safe, effective and undamaged.

Monitor the work area and equipment to make sure that:



- Safety equipment remains effective and has not been damaged.
- Fall protection equipment is in place and adjusted appropriately to cater for movement during work.
- Scaffold components and fall barriers (e.g. safety nets) are in place during work.
- Existing hazard controls are monitored and modified in relation to changing work practices or site conditions.
- New hazards are identified and appropriate hazard controls are implemented to deal with them.

Remain aware of changing weather conditions including strong winds or rain. These may create a hazard on site, risking health and safety of workers. You may need to adjust your work methods and techniques if hazardous weather conditions arise, or stop work altogether if necessary.

Sudden strong gusts of wind may cause workers to lose their balance or cause materials or equipment to be swept over the edge of the work area. Rain may cause the surface of the work area to become slippery.

3.1.6.2 Communications

Make sure you select the most appropriate communication equipment and methods to coordinate the scaffolding task.

This communication could be between you and plant operators, or other members of the scaffold team.

Communications need to be clear especially between workers who are on different levels of the scaffold during the erection process.

It is important that you are able to communicate effectively, this will allow you to:

- Coordinate the movement of scaffold components.
- Work to the schedule or plan during the erection process.
- Ensure the stability of the scaffold and the safety of the workers in the area.



3.1.7 Installing a Cantilevered Crane Loading Platform

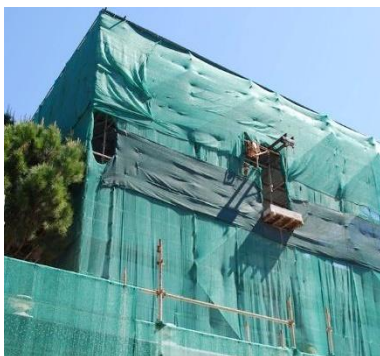

Cantilevered crane loading platforms (CCLP) should be installed in accordance with procedures and the supplier's or manufacturer's instructions for that particular model.

CCLPs need to be braced and secured into place in order to prevent sideways movement. There are two common methods for doing this:

1. Anchoring the needles supporting the CCPL into place using bolts through the needle and the structure it is placed on.
2. Using props that are secured at the roof and base to prevent the platform from shifting laterally (up and down) under load.

In some circumstances it may be necessary to use both methods at the same time.

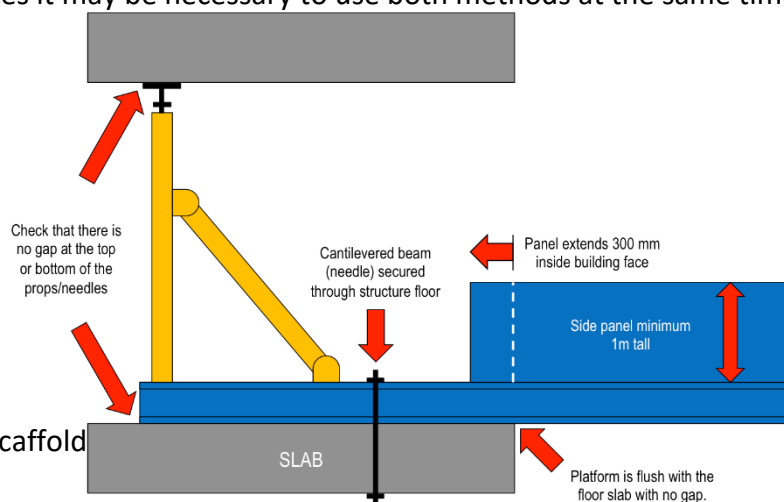

Once in position the platform should be flush with the floor. If this is not possible, appropriate ramps can be installed to resolve this problem.

Solid panels not less than 1m high should be fitted to the sides of the landing and extend at least 300mm inside the building's face.

Platforms facing a public roadway should not extend beyond the line of the overhead protection provided for the public.

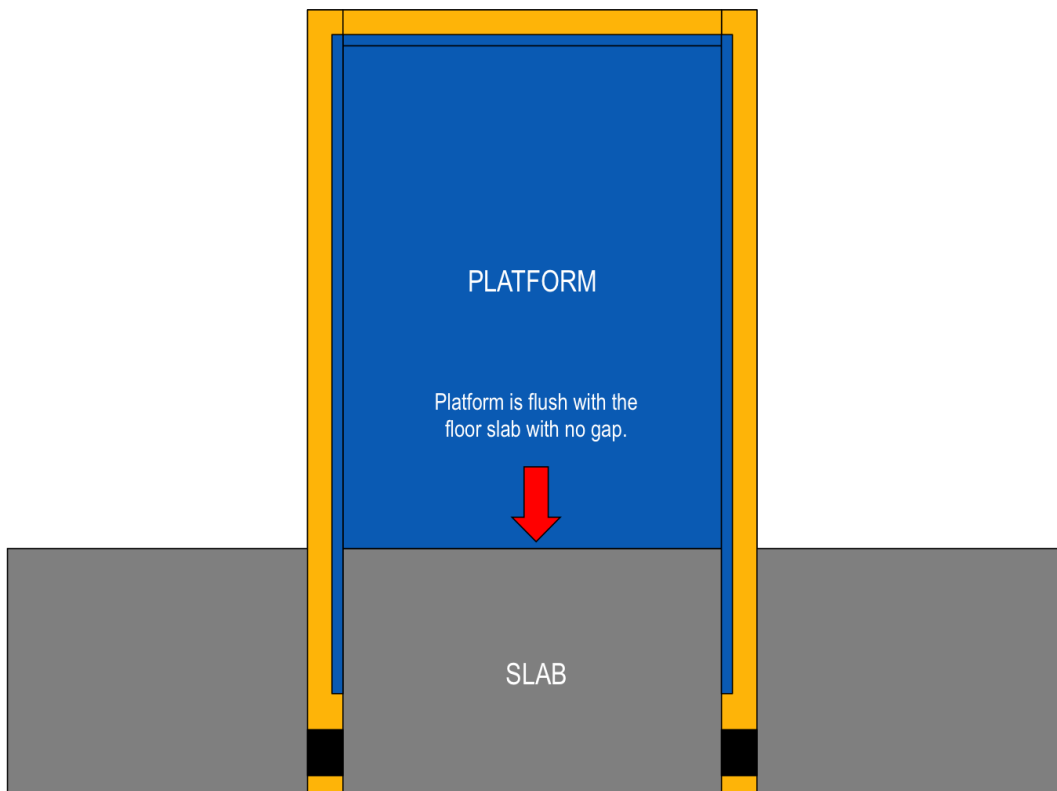

You need to conduct an inspection once the platform has been installed, before it can be used. Make sure you check for the following:

Platform Inspection Checklist:

- All bolts or connectors are secured and tightened in position.
- All props are plumb and are adequately secured in place.
- There is no gap between the platform floor and the slab.
- Adjustable props are set with minimal jack extension.
- Rear handrails are in position.

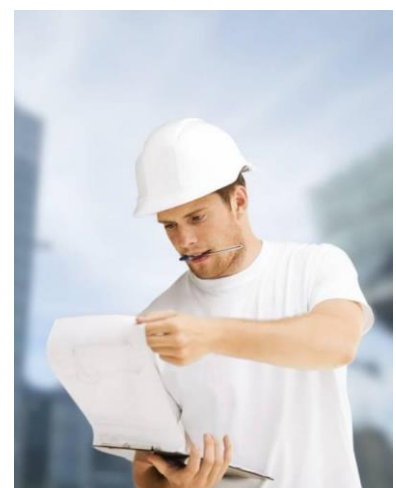

- Side panels and gates are fixed into position.
- Any required engineering approval is obtained.
- The work load limit is displayed.
- The tare weight has been identified.

3.1.7.1 Relocating a Cantilevered Crane Loading Platform



Relocation of a CCLP must be carefully planned out. Before the CCLP is moved you must make sure the areas where the platform is being moved from and to are barricaded to prevent unauthorised people entering the area.

The area below the CCLP should also be barricaded and spotters used if necessary.

Fall arrest equipment must be in place where the relocation of the CCLP results in an unprotected edge, before the CCLP is moved.

All personnel must wear a static line with fall arrest harness and lanyard. If possible, edge protection should be installed as soon as the CCLP is removed.

3.1.7.2 Safe Use of a Cantilevered Crane Loading Platform

When using a cantilevered crane loading platform:

- Make sure the gates are closed at all times. They may be open when moving long loads.
- Keep all platforms clean and clear of loose materials or debris.
- Only use a cantilevered crane loading platform in the manner for which it was designed. Any alterations or different use of the platforms should be to an engineered design.



Rolling cantilevered crane loading platforms can be rolled in and out of a building. Make sure that braces, locking pins and spreader bars are in position and secured and that the tie bar at the rear of the platform is used at all times.

3.1.8 Installing Perimeter Safety Screens and Shutters



Perimeter safety screens and shutters are designed to prevent personnel and any debris, tools or materials falling from a height.

These generally extend one floor above the floor they are installed on.

The top of the screen should be high enough to provide edge protection for the floor that is to be built before any personnel can gain access to it.

The framework supporting the screen needs to be able to bear the load of the screen. The mesh needs to be of minimum gauge 2.5mm, and have a maximum mesh opening size of:

- 25mm nominal where no lining is used.
- 50mm nominal where lining is used.



Gaps between the screens and the structure should not exceed 25mm.

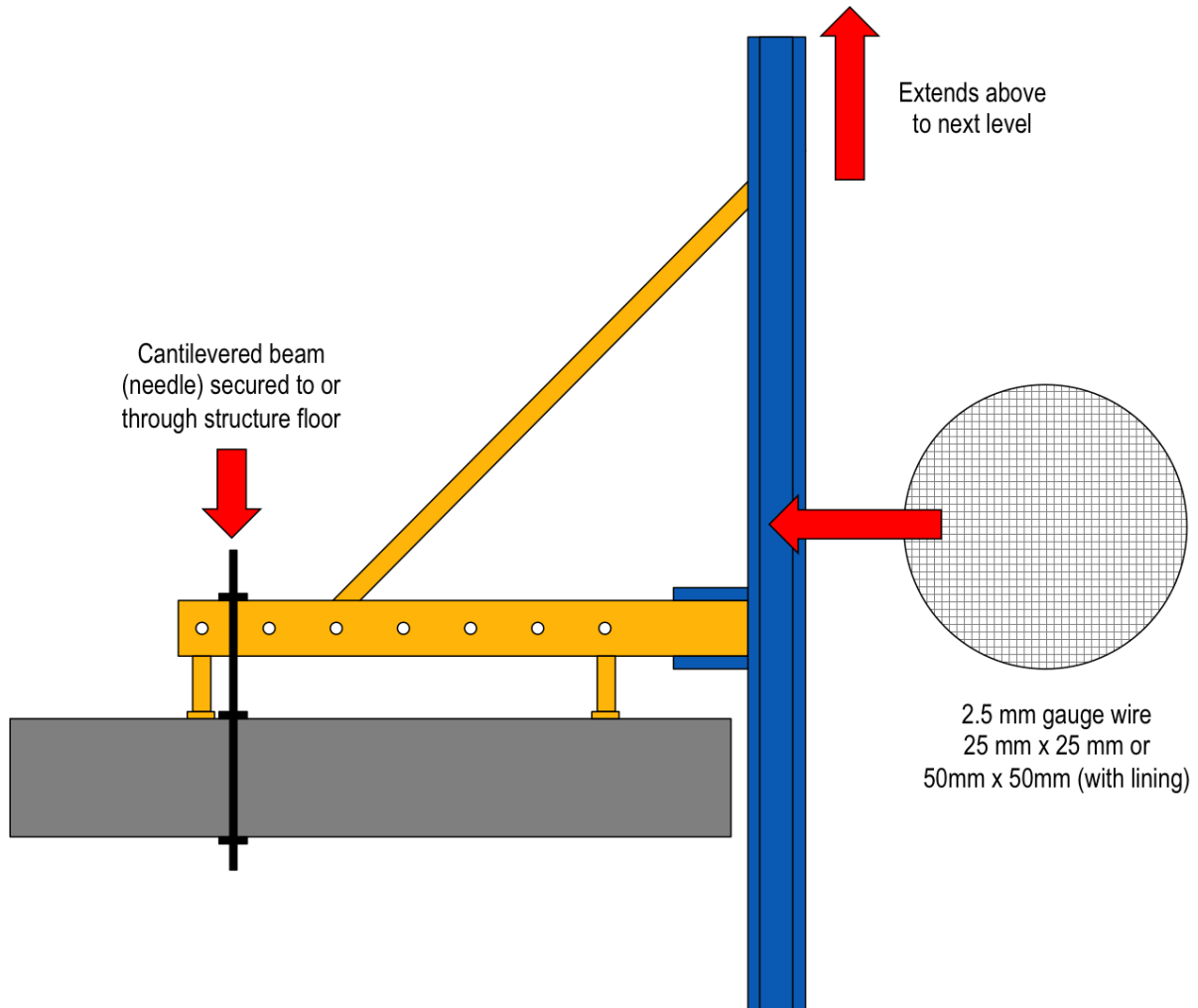

Perimeter safety screens may be installed using needles or props provided by the manufacturer and designed to be used with a specific safety screen system.



These should be secured adequately to support the weight of the screens.

There may be different options provided by manufacturers to secure any supporting structures to concrete or other structural members.

Always install the safety screen system in accordance with procedures and the manufacturer's specifications.

Always conduct work safely including the use of a fall-arrest system whenever working near an exposed edge during the installation or removal of safety screens and shutters.

3.1.9 Setting Up a Mast Climber

The mast climber should be placed with the mast inwards where the mast is tied to the building.

Always make sure that the sequence of installation does not put any personnel in any danger and that no part of the equipment is overstressed or overburdened.

The outriggers must be fully extended and locked (as per manufacturer's recommendations for the actual setup of the machine) before the erection process may begin.



Packing must be used depending on the ground conditions, and to ensure that the towers are level, plumb and aligned. Never setup the mast climber over a trench or excavation.

If the mast climber is being set up on a suspended concrete slab, make sure you get a certificate of compliance from an engineer first confirming that the floor can support the weight of the load.

A free standing mast should not be used in high winds.

The mast must be anchored to the building at spacing determined by an engineer or the manufacturer.

An engineer's certificate may be required before tying the mast climber to a structure or building. The structure or building must be checked to ensure that it can withstand the strain that may occur in high winds. If the building is not strong enough to withstand the force of the load, refer to the manufacturer's specifications or an engineer.



Once the mast climber has been installed you will need to test all of the limit switches and erect appropriate fencing, barriers and gates to prevent unauthorised access to the area.

Signs displaying the rated capacity of the mast climber will need to be installed where they can be clearly seen by any personnel authorised to use it.

Always check that the finished mast climber meets the design specifications provided by the manufacturer.

3.2 Recording Scaffold Erection and Modification



After erection or modification of scaffold there are certain checks and documentation to be completed. This is to make sure that the scaffold meets requirements and aligns with the details in the original scaffold plan.

3.2.1 Inspecting and Documenting Scaffold Erection

Once the scaffold has been erected it will need to be inspected by a competent person for the following:

- Stability and condition of structure.
- Standards secure, plumb, correctly joined and spaced.
- Ledgers secure, level, correctly joined and spaced.
- Transoms/putlogs secure, level, correctly joined and spaced.
- Bracing and ties in correct position and properly fixed.
- Correct footings used for surface.
- Sufficient and safe access to all working platforms.
- Platforms positioned and secured correctly. Correct number and dimensions of platforms for duty.
- Edge protection correctly installed.
- Sheeting/screens/shutters correctly installed.
- Scaffold matches structural plan.
- Other structures (e.g. mast climber, cantilevered crane loading platform) installed correctly.



Once a scaffold erection, inspection or modification is completed, a licensed scaffolder needs to place an inspection record on the scaffold.

The inspection record needs to include the following details:

Record Detail	Explanation
Location	Unit / plant number followed by area of plant.
Ref. No.	Work Order number.
Date Erected	Date the erection of the scaffold was complete.
Requested By	This should be the Team leader/Plant Area Coordinator etc., requesting the scaffold. (This may be on the Work Order).
Built By	This is the company who built the scaffold.
Name of Competent Person	Print the name of the competent person/certified scaffolder.
Signature	Signature of competent person/certified scaffolder.
Light Duty 225kg	As per AS/NZS 4576.
Medium Duty 450kg	
Heavy Duty 675kg	

3.2.2 Modifying or Inspecting a Scaffold



Where practicable, the competent person/certified scaffolder who erected the scaffold, and whose name appears on the inspection record, is to be the person to perform scaffold modifications and inspections.

Prior to modifying scaffold, the scaffolder is to:

- Remove the inspection record.
- Replace with a notification inspection record detailing the date and time of the modification or inspection, the name of the person performing the modification or inspection and the reason for the alteration where relevant.

It should contain the following information:

- The name of the client that the work has been done for.
- Address of the worksite where the tasks were completed.
- The location of the scaffold in the worksite.
- The type of scaffold that was erected (e.g. modular, mobile).
- The height and length of the scaffold.
- The number of lifts and bays in the scaffold.
- The duty category of the scaffold (e.g. light, medium, heavy, special).
- The type of access available (e.g. ladder, ramp, stairway).
- Design reference number.
- Date and time of handover.
- Name and signature of the responsible person.



An example of a handover certificate can be found in **Appendix B**.

3.3 Dismantle Scaffold and Scaffold Equipment

When work on the scaffolding has been completed it is time to dismantle the structure and any associated equipment. You need to do this safely and methodically and maintain good communication with other personnel on site while doing so.



3.3.1 Procedures for Safe Dismantling of Scaffolding

Always follow the manufacturer's instructions when disassembling equipment to ensure the safety of all personnel in the area, to maintain stability during the process and to prevent any damage to the plant and equipment.

Dismantle the scaffold according to the correct procedures.

- Work safely at heights utilising safety equipment such as falls arrest systems.
- Start from the highest lift and dismantle the scaffold downwards one lift at a time.
- Only remove ties and braces from the lift you are dismantling.
- Do not remove all the ties and braces first.
- Clear the platforms of all equipment and loose material.



Once they are no longer needed, safety systems such as static lines, fall-arrest harnesses and safety nets should be dismantled according to the correct sequence and procedures.

They should then be removed from the work area.

Always work methodically and follow site procedures to avoid any unplanned collapse of plant and equipment.

Unplanned collapse can result in serious injuries to personnel and damage to equipment and materials.

3.4 Incidents and Emergency Response

Emergencies can happen quickly and without warning when work is being conducted at heights.

If all necessary precautions, hazard control measures and safety equipment have been used then the risk of serious consequences is reduced.



However, you should always be prepared to take action in an emergency situation, even if that action is as simple as calling for help.

3.4.1 What is an Incident?



An incident is:

- An accident resulting in personal injury or damage to property.
- A near miss or dangerous occurrence which does not cause injury but may pose an immediate and significant risk to persons or property, and needs to be reported so that action can be taken to prevent recurrence.

All incidents **MUST** be reported!

3.4.1.1 Responding to an Incident

If an unsafe incident or event occurs during scaffolding operations you should:

- 1** Stop work immediately and if it is safe to do so.
- 2** Assess the problem.
- 3** Find a solution if possible (resolve the problem).
- 4** If needed, seek advice and assistance.
- 5** Report the incident according to procedures.

3.4.2 Workplace Emergencies

Site emergencies may include:

- Injury to personnel.
- Fire (electrical, chemical, gas, mechanical, paper, wood or natural).
- Gas leak.
- Toxic and/or flammable vapour emissions.
- Vehicle/machine accident.
- Chemical spill.
- Structural collapse.



3.4.2.1 General Emergency Response

In the case of an emergency:



1. Remain calm.
2. Raise the alarm with your supervisor, safety officer, other people at the workplace and emergency services (Dial 000).
3. Communicate the following details:
 - a) That there is an emergency situation.
 - b) The nature of the emergency.
 - c) Where any unsafe areas are.
4. Evacuate if necessary (refer to site emergency plans).

3.4.2.2 General First Aid

First Aid kits must be supplied by your employer. The location of these kits should be clearly marked with signage.

In the case of an emergency where somebody requires first aid, notify your supervisor or first aid officer and they will take action.



3.4.3 Incident Relating to the Use of Fall-Arrest Systems



If a worker who is using an individual fall-arrest system falls from an edge, the system may act as a pendulum.

This may result in the worker hitting the ground (called 'swing down') or swinging back into the building or structure (called 'swing back').

These situations may also be referred to as 'the pendulum effect'.

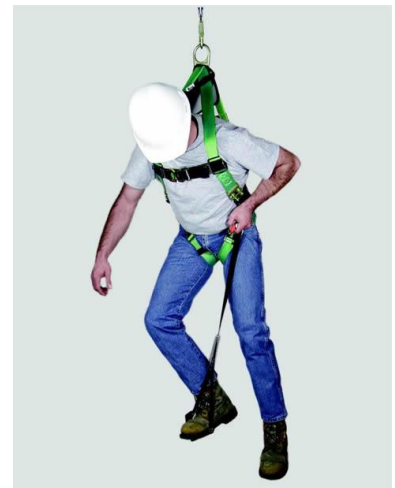

Swing down can occur if the lanyard slides back along the perimeter edge of the roof as a worker falls, until it is vertical.

When this happens, the worker may hit the ground (or lower level), or the lanyard may break from being dragged across the edge of the roof.

3.4.3.1 Suspension Trauma

Suspension trauma can occur with a fall-arrest system when a person has an arrested fall and is suspended in an upright, vertical position with the harness straps causing pressure on the leg veins.



The lower legs' capacity to store large amounts of blood reduces the return of blood to the heart, slowing the heart rate, which can cause the person to faint.

This may lead to renal failure and eventually death, depending on a person's susceptibility. This condition may be worsened by heat and dehydration.

3.4.3.2 Preventing Suspension Trauma



The following techniques can be used to help prevent suspension trauma in a person who is hanging in a fall-arrest harness:

- Never work alone when using a harness as fall protection.
- Wherever possible use a fall-arrest harness that allows the legs to be kept horizontal.
- If possible keep the time a worker spends in suspension after a fall limited to less than five minutes. This can be achieved by providing foothold straps or a way of placing weight on the legs.

If you find yourself in a situation where you are suspended in a fall-arrest harness after a fall, attempt the following action:

1. Move your legs in the harness and push against any footholds to relieve pressure on your upper legs.
2. Move your legs as high as possible and tilt back so that you become as horizontal as possible.

The quickest possible rescue of a person suspended in a full body harness is vital.

For this reason, workers should be capable of conducting a rescue of a fallen worker and be familiar with on site rescue equipment and procedures.

If a worker has fallen and is hanging suspended in a safety harness for a prolonged period of time (5 to 30 minutes) it is absolutely vital that first aid procedures are implemented as quickly as possible.

3.4.3.3 First Aid for Suspension Trauma



In accordance with Australian Resuscitation Council (ARC) guideline 9.1.5, first aid management of suspension trauma should be carried out as follows:

1. Call for an ambulance (dial 000 or 112).
2. If unconscious, manage the victim according to basic life support principles. If conscious, rest the victim in a comfortable position, ideally lying down, and provide reassurance.
3. Loosen or remove the harness.
4. Administer oxygen if available.
5. Look for and manage associated injuries in the victim, especially if they have fallen or been electrocuted.
6. Monitor the signs of life at frequent intervals.

Remember, care of the airway takes precedence over any injury.

3.4.4 Report All Hazards, Incidents and Injuries

Depending on the nature and severity of the situation you may need to report to:

- Your supervisor.
- Emergency services (e.g. police, ambulance, fire brigade and emergency rescue).
- WHS regulatory authority (e.g. WorkSafe, WorkCover).



Ask your WHS representative or supervisor at the site office for the relevant forms and procedures for reporting hazards, incidents and injuries.

3.5 Conclude Scaffolding Operations



Once the scaffolding task has been completed you will need to carry out any other tasks as required by site procedures.

This may include:

- Tidying the work area and removing rubbish or materials from the site.
- Inspecting scaffolding and associated equipment for defects.
- Isolating defective equipment in accordance with procedures and recording and reporting defects.
- Removing hazard control measures.

3.5.1 Tidy the Work Area

Once the work has been completed you need to clean up the work area. Remove any leftover materials and debris created by the task; these can cause a tripping hazard for personnel.

Dispose of any debris and rubbish properly without impacting negatively on the environment.

Divide up recycling and other waste materials for correct removal and processing.



3.5.2 Inspect All Scaffolding Equipment



All equipment needs to be inspected once all scaffolding operations have been completed. Check for any damage that may have occurred while the equipment was in use. The manufacturer's instructions may have inspection checklists relating to different types of equipment that should be referred to.

It is important that you record inspections, services, faults and repairs in the relevant documentation as this information may be reviewed as evidence in incident and accident investigation.

Make sure that you clean the equipment if necessary and that all scaffolding equipment and parts are stored correctly in accordance with site procedures.

3.5.2.1 Isolate Faulty Equipment and Report Defects

Any defective equipment needs to be properly isolated and removed from service to prevent anybody from accidentally using it.

Standard procedures for isolating equipment and recording and reporting defects need to be followed.



3.5.2.2 Storing Tools and Equipment



Once all scaffolding equipment has been inspected for faults, it should be stored appropriately.

Each workplace will have systems in place for the storage of tools and equipment. You can find these in any relevant workplace policies and procedures.

Your induction to the work-site should include the specific storage procedures you need to follow. If you do not know how to store scaffolding equipment speak to your supervisor or manager for information and instructions.

3.5.3 Remove Hazard Control Measures

Any hazard controls that are no longer required need to be removed from the work area and stored according to procedures.

Inform any relevant personnel that the work area has been returned to normal conditions and that your tasks have been completed.



Appendix A – Work Method Statement

WMS Name:	WMS Created By:	Date of Creation:
WMS Summary:		Last Reviewed Date:

Company/Contractor Details:	Project Details:
Name:	Client:
ABN:	Contact Name:
Address:	Site Address:
Contact Number:	Contact Number:
Email:	Start Date:

How to complete this WMS:

- 1. CONSULT:** Consult with all persons who will be involved in the completion of the work.

2. **LIST:** List each of the steps in the task work being done.
3. **IDENTIFY:** Describe the health and safety hazards and risks arising from each step in the work.
4. **RISK ASSESSMENT:** Review the level of risk associated with each hazard listed.
5. **CONTROL:** Describe how the risks will be controlled, and describe what hazard control measures will be put in place.
6. **RESPONSIBILITY:** Allocate a person to be responsible for the hazard control measure.
7. **REVIEW:** Review the effectiveness of the control measures and apply further hazard control measures as required.

Risk Analysis Matrix

Use this table to determine the level of risk associated with an identified hazard.

	Consequence				
	1. Insignificant	2. Minor First Aid Required	3. Moderate Medical Attention and Time Off Work	4. Major Long Term Illness or Serious Injury	5. Catastrophic Kill or Cause Permanent Disability or Illness
Likelihood					
1. Rare	Low	Low	Moderate	Moderate	Moderate
2. Unlikely	Low	Low	Moderate	Moderate	High
3. Possible	Low	Moderate	High	High	Extreme
4. Likely	Moderate	Moderate	High	High	Extreme
5. Almost Certain	Moderate	High	High	Extreme	Extreme

Risk Level	Action
Extreme	This is an unacceptable risk level The task, process or activity must not proceed .
High	This is an unacceptable risk level The proposed activity can only proceed, provided that: <ol style="list-style-type: none"> 1. The risk level has been reduced to as low as reasonably practicable using the hierarchy of risk controls. 2. The risk controls must include those identified in legislation, Australian Standards, Codes of Practice etc. 3. The risk assessment has been reviewed and approved by the Supervisor. 4. A Safe Working Procedure or Work Method Statement has been prepared. The supervisor must review and document the effectiveness of the implemented risk controls.
Moderate	This is an unacceptable risk level The proposed activity can only proceed, provided that: <ol style="list-style-type: none"> 1. The risk level has been reduced to as low as reasonably practicable using the hierarchy of risk controls. 2. The risk assessment has been reviewed and approved by the Supervisor. 3. A Safe Working Procedure or Work Method Statement has been prepared.
Low	The proposed task or process needs to be managed by documented routine procedures, which must include application of the hierarchy of controls.

Work Method Statement

Work Step	Associated/Identified Hazards	Risk Level	Hazard Controls	Revised Risk Level	Person Responsible
Work your way through each step in the work process, giving a brief description of what is required at each stage.	What hazards can be identified for this step?	What is the risk level?	What hazards controls will be put into place to deal with the identified hazards for this step?	Has the risk been reduced?	Who is responsible for carrying out the work and maintaining the hazard controls?

Work Step	Associated/Identified Hazards	Risk Level	Hazard Controls	Revised Risk Level	Person Responsible
Work your way through each step in the work process, giving a brief description of what is required at each stage.	What hazards can be identified for this step?	What is the risk level?	What hazards controls will be put into place to deal with the identified hazards for this step?	Has the risk been reduced?	Who is responsible for carrying out the work and maintaining the hazard controls?

Appendix B – Handover Certificate

Handover Certificate		Handover Date:			
		Handover Time:			
Client Name:		Contact Name:			
Worksite Address:		Scaffold Location On Site:			
Type Of Scaffold:					
Duty Category (Please Circle)	Light	Medium	Heavy	Special	
Number Of Lifts:			Height Of Scaffold:		
Number Of Bays:			Length Of Scaffold:		
Type Of Access:			Design Reference Number:		
NOTES:					
Name Of Person Responsible:					
Signature Of Person Responsible:					